

inVia™ confocal Raman microscope



Renishaw inVia: the world's best selling high-performance Raman microscope

- Designed, developed and refined over two decades to make it the most trusted Raman instrument on the market
- Superior, research-grade Raman microscope for your current and future needs
- Designed using Renishaw's vast experience of precision and innovative engineering
- Built to last; upgrade, reconfigure, or customise - inVia is a sound investment
- Available in three models: inVia Basis; inVia Reflex and inVia Qontor
- A range of options and accessories to suit your analytical requirements and budget

Trust inVia for reliable, high quality results



Why people choose inVia

Renishaw is a global company, with a worldwide network of scientists and engineers who are on-hand to provide you with expert product, technical and applications support.

Exceptional performance you can rely on

inVia comprises a research-grade microscope coupled to a high-performance Raman spectrometer. It is simple to operate yet delivers outstanding performance—high signal throughput, combined with high spectral resolution and stability—giving reliable results, for even the most challenging measurements.

inVia's highly efficient optical design produces the best Raman data, even from minute traces of material. If you need to easily and reliably produce both rich, detailed, chemical images and highly specific data from discrete points, then inVia is the ideal system for you.

Unparalleled flexibility and upgradability

inVia is totally flexible and can be upgraded, modified and customised, without compromising performance. Add accessories, lasers, fibre optic probes or combine Raman with other techniques; whichever configuration of inVia you choose, you will have the most flexible and sensitive Raman system on the market. If our standard products don't match your exact needs, then our special products team can develop a custom solution to meet your requirements.

Quality, reliability and longevity

The inVia confocal Raman microscope is designed utilising Renishaw's vast experience of precision and innovative engineering. inVia is an exceptional, high-quality, high-performance system that has been developed and refined over two decades to make it one of the most trusted Raman instruments on the market. Choosing Renishaw as your Raman partner is a sound investment and your inVia is built to last.

A Raman system from Renishaw comes with the lifetime of support and service you expect from a specialist provider; instrument diagnostics, servicing and adjustment can be done remotely, or by a personal visit from a member of our global service team.

No other Raman microscope manufacturer offers the same levels of flexibility and sensitivity in one system.

Find out more at www.renishaw.com/inVia

Key benefits



High performance

inVia delivers outstanding performance, providing you with the best data from any sample in the shortest time.



Sensitive

See even the weakest Raman scatterers and get spectra from thin films and monolayers.



Powerful

Use inVia for both Raman and photoluminescence measurements to obtain information on the electronic and vibrational structure of your materials, or combine with other analytical techniques for a powerful, comprehensive solution.



Automated

inVia's full automation handles the changing of laser wavelengths, filters and gratings for you. inVia also maintains focus, system alignment and calibration, so you can concentrate on getting results, not having to adjust your Raman system.



 **Flexible**

inVia is completely configurable, incredibly flexible and totally upgradable. You can analyse the widest range of samples, under different experimental conditions now and in the future.

 **Repeatable results**

Rely on inVia to produce results you can trust. With its outstanding performance you can be confident that inVia will deliver repeatable results time and time again – no matter how challenging the experiment.

 **Easy to use**

inVia's automation and optional sample enclosure (which eliminates ambient light) maximise operational efficiency, even in busy laboratories with multiple users.

 **A full range of imaging technologies**

inVia has a comprehensive suite of mapping and imaging techniques. Use these to generate detailed, information-rich Raman images, of both 2D areas and 3D volumes.

 **Analyse irregular samples**

inVia Qontor's live automated focus tracking technology enables the analysis of samples with uneven, curved or rough surfaces and maintains focus in both white light video and Raman modes.



Key features



High optical efficiency

Fast and sensitive analysis

Renishaw's engineers have used their vast experience of precision and innovative design to make inVia the most sensitive Raman instrument available. They chose a stigmatic on-axis spectrometer which gives high optical efficiency, excellent stray light rejection and unparalleled sensitivity. With inVia you can study very weak Raman signals and rapidly analyse even minute traces of material.

High spectral resolution

Analyse a wide range of samples

Configure inVia to resolve narrow spectral features, so you can distinguish between close Raman bands and differentiate very similar materials, such as complex mixtures.

High spectral stability

Get consistent, reliable data

With its rigid, lightweight baseplate, and precision kinematic mounts, inVia provides the highest levels of instrument stability, enabling you to monitor minute shifts in Raman band position.



We like the ergonomic design and the ease of operation; inVia's high efficiency; the ability and speed to change a laser line without moving the sample under study. We like the internal calibration of frequency, the possibility of automatic adjustments, the different imaging modes – from the traditional point-to-point to the rapid StreamLine mode. I have also to stress the high efficiency of the Renishaw team, to solve any problem or question we have on the machine.



CNRS Orléans (France)

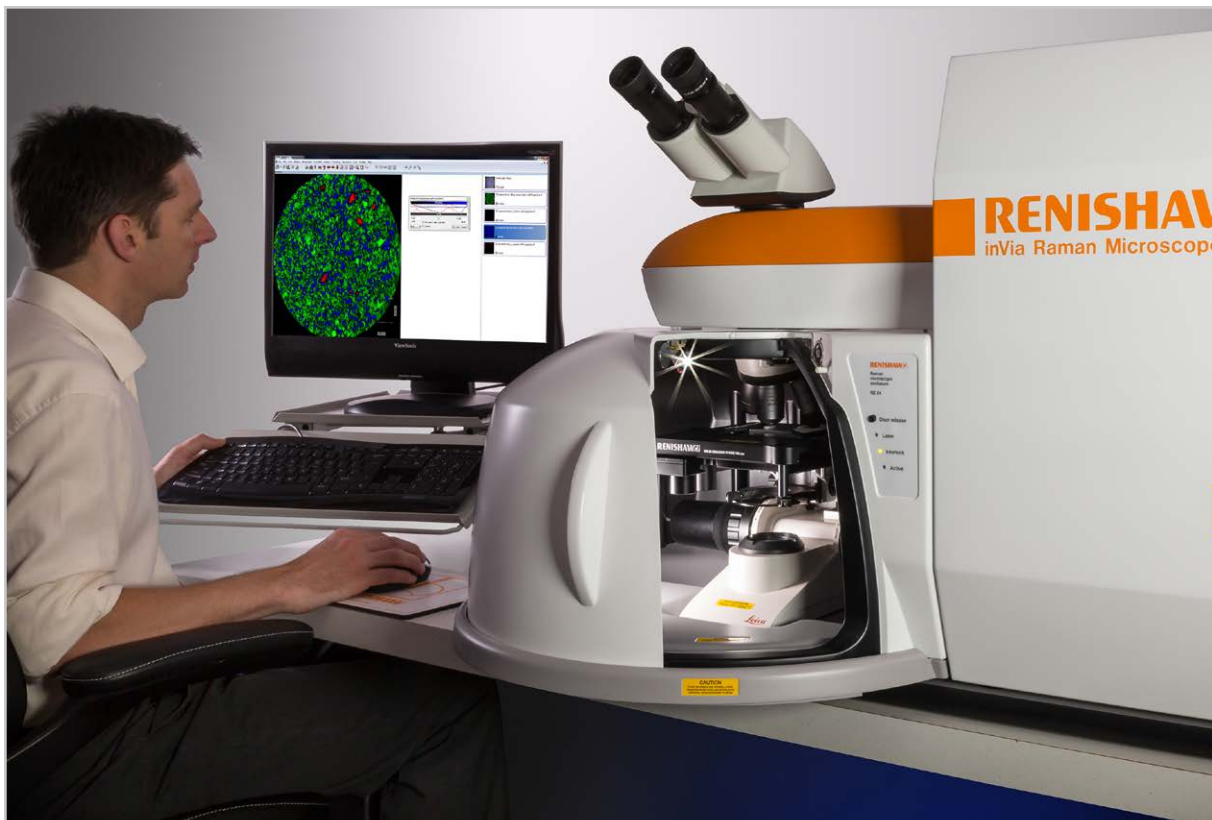

Key features

High spectral bandwidth

Performance, without compromise

inVia's operating range can extend from the deep UV to the far IR. Choose the best combinations of lasers, detectors, filters and gratings, to give you the best Raman data in the shortest possible time.

Broad-range artefact-free spectra

Raman and photoluminescence measurements

Achieve extended coverage with Renishaw's **SynchroScan™** technology. This enables the collection of light over a very wide spectral range, without artefacts and without sacrificing resolution. inVia can, for example, acquire a high resolution spectrum from across the entire visible/near infrared region in one single continuous acquisition.

Low wavenumber performance

Analyse close to the laser line

inVia supports a wide range of Rayleigh filters, including filters that you can use to study low wavenumber Raman features efficiently and easily.

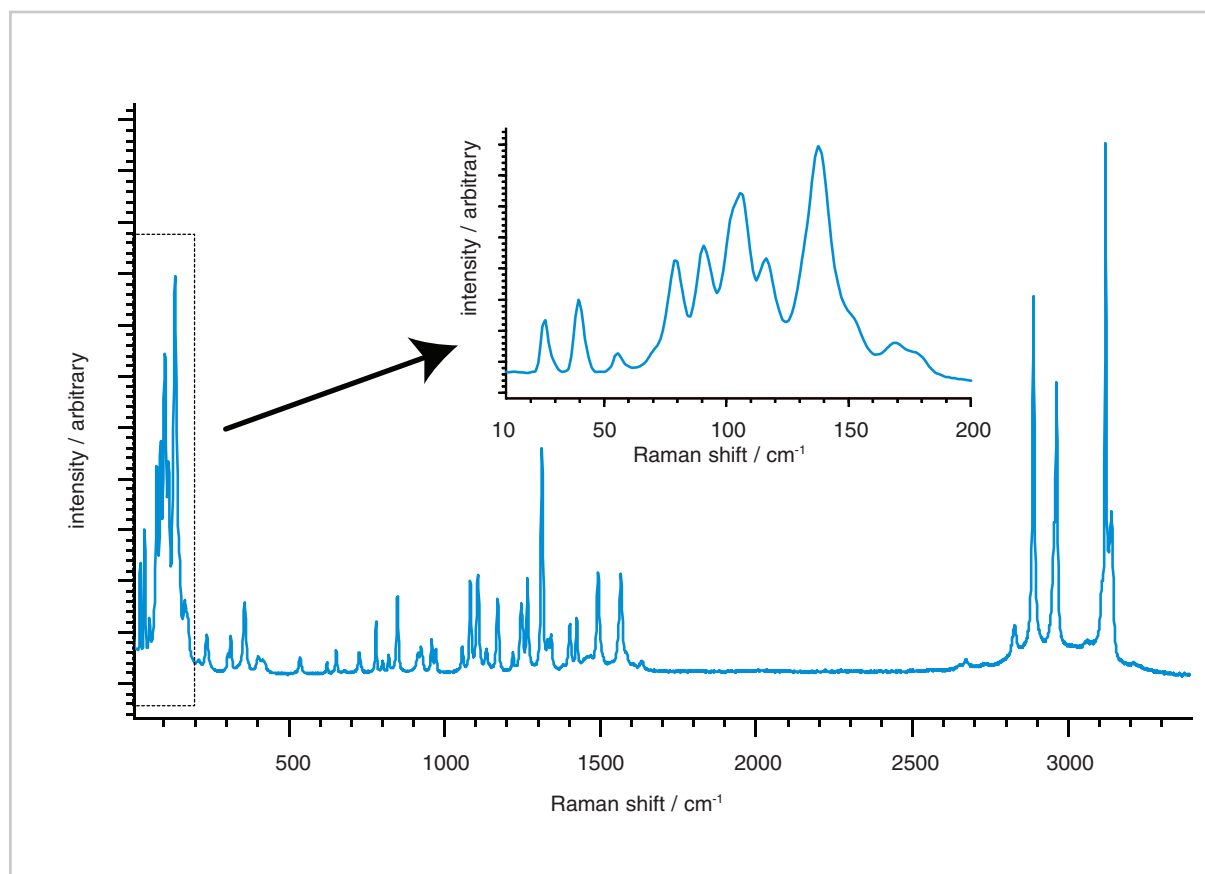

A Raman spectrum of L-histidine, showing the lattice modes (inset), fingerprint and C-H ranges, at high spectral resolution. It was acquired in a single spectral collection using SynchroScan™.

Highly sensitive detectors

Cutting edge technology

inVia Raman microscopes use Renishaw's own ultra-low noise, ultra-high sensitivity CCD cameras so you get the best results in the shortest possible time. Should you wish to add more, inVia can be fitted with up to four detectors, such as electron multiplied (EM) detectors and InGaAs arrays.

Truly confocal performance

Configure exactly to your needs

Achieve the highest spatial resolutions possible, limited only by the inherent diffraction limit of light. The inVia Raman microscope's **EasyConfocal** optical system offers a truly confocal capability with high spatial resolution, without compromising ease-of-use, stability, and optical efficiency. Switch, with ease, from sub-micrometre high-resolution measurements to large scale averaging of bulk samples.

High performance microscope

Leica for quality, efficiency and reliability

Leica Microsystems' research-grade microscopes are the standard option for inVia and can be equipped with high magnification objective lenses so you can achieve high spatial resolution.

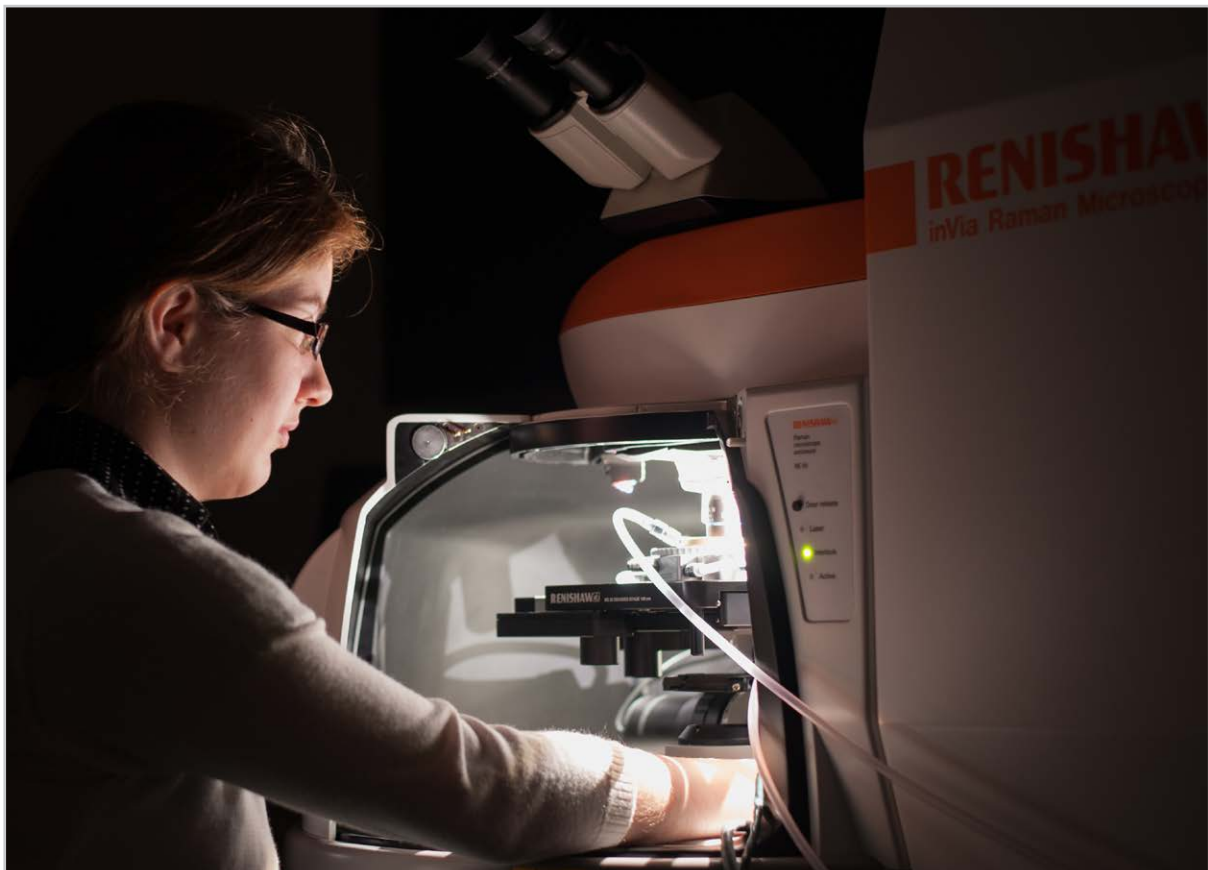

inVia supports a wide range of environmental and sampling accessories. Here, a mapping experiment is being performed at high temperature.

Key features

Extended sample viewing

Clearly see your sample

Binoculars, with two working eyepieces, not only enable the sample to be viewed directly, but also provide a large field of view. You see a much larger area—and gain instant feedback—as you move the sample.

When inVia is equipped with a sample stage, such as Renishaw's high speed encoded stage (HSES), it can generate an image of the sample that covers an area much larger than the field of view of the microscope. You can use this image to easily define locations for subsequent data collection.

Multiple lasers

Get the best data, whatever your sample type

inVia's wide range of directly coupled laser excitation options—from the near-infrared to the deep ultraviolet—ensures you can tailor your instrument to match your needs. For example, you may wish to minimise fluorescence or induce resonance. inVia normally accommodates two or three lasers as standard but can be configured to use as many lasers as you need. Optimised laser delivery paths ensure you achieve the best results from each laser.



Renishaw's patented motorised stage uses encoders to keep track of its position, even when you move it manually.

Generate high quality Raman images

Crisp, clear chemical images

inVia offers a complete range of imaging technologies that enable you to acquire data from points, lines, areas, and even volumes. **StreamLine™**, **StreamHR™** and **True Raman Imaging™** are unique to Renishaw and generate outstanding Raman images.

Fully automated

inVia is easy to use and maintain

inVia's automation removes the need for manual operator intervention. When you change key components, like filters, lasers and gratings, inVia will automatically reconfigure its optics and optimise its alignment. This makes analysis more efficient, which is perfect for busy laboratories with multiple users.

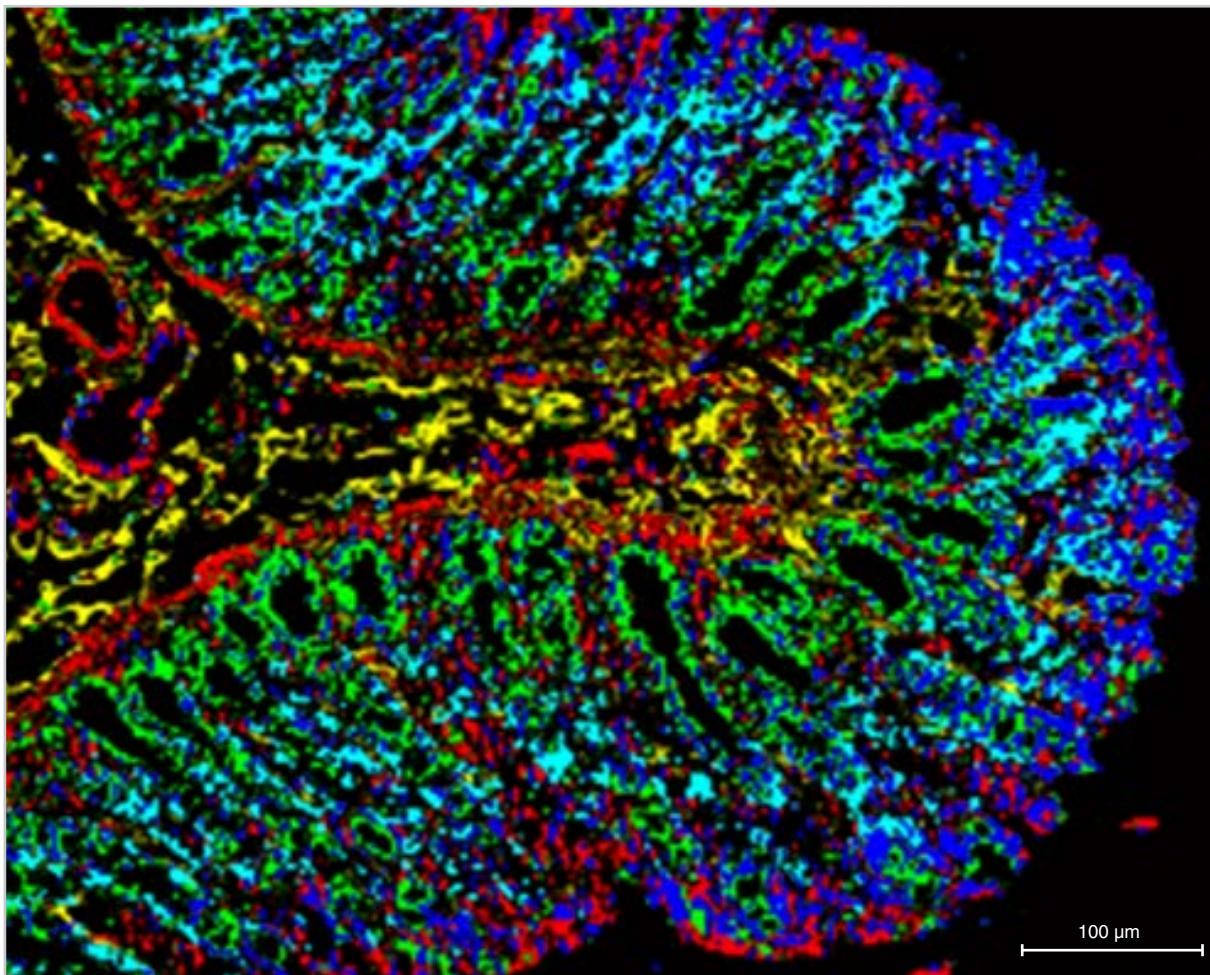

StreamLine is ideal for examining delicate biological samples. This high contrast image of a healthy rat colon crypt shows the different cell types and anatomical layers. Data courtesy of Riiana Gaifulina, University College London, UK

Key features

Maintain focus in real time

Sample surface/interface tracking technology

Use LiveTrack™ automated focus tracking technology to acquire, in real-time, accurate and repeatable spectra and topography from samples with extensive variations in height. Create stunning 3D images of uneven, curved or rough surfaces without the need for pre-scanning.

Sampling flexibility

Access and control your sample, whatever your experimental needs

The inVia offers the widest range of configurations and accessories on a single Raman system.

- A range of objective lenses and environmental cells ensures your samples can be analysed under different environmental conditions.
- For samples that are too big to fit under the microscope, the flexible sampling arm lets you position your objective exactly where you need it.
- inVia supports both research-grade upright, inverted and open frame microscopes, as well as fibre optic probes for long distance remote analysis.

Powerful software

Acquire, analyse and display high quality Raman data

Renishaw's WiRE (Windows-based Raman Environment) software is tailored specifically for Raman spectroscopy. It controls the acquisition of spectra and provides a full suite of data processing and analysis functions.

Raman polarisation option

For analysis of the symmetry and orientation of samples

Optional polarisation enables the control of both laser and spectrometer polarisation (polariser/analyser). With these options you can determine the orientation of crystals (such as microcrystals) and also depolarisation ratios for liquid samples.

Combine for even more power

Add AFM, SEM, CLSM...

Combine the power of Raman with other analytical techniques, such as scanning probe microscopy (AFM and TERS), scanning electron microscopy (SEM), or confocal laser scanning microscopy (CLSM). inVia's flexible design also allows it to be combined with numerous other specialist techniques, including X-ray diffraction systems at synchrotrons, and neutron diffraction systems at beamlines.

Safety

Safe to use, without compromising simplicity or ease-of-use

inVia is fully equipped with laser safety interlocks and an optional sample enclosure. Depending on the configuration and lasers used, it is Class 3B, Class 4, or Class 1 laser safe.



The performance of the system, together with the excellent support from Renishaw, made the decision [to buy an inVia] an easy one for us..... inVia is an efficient, easy-to-use, easy-to-share system.

Boston University (USA)



The key benefit [of inVia] is the ultra-high speed data acquisition system, which results in a higher sensitivity to measuring stresses in the materials compared to other Raman systems.

Kwansei Gakuin University (Japan)



We are impressed with the sensitivity of the system, the reproducibility of the results and the stability of the 532 nm laser.

Rijksmuseum (Amsterdam)





Make automated Raman measurements at high temperatures (up to 1500 °C).

LiveTrack: focus tracking technology

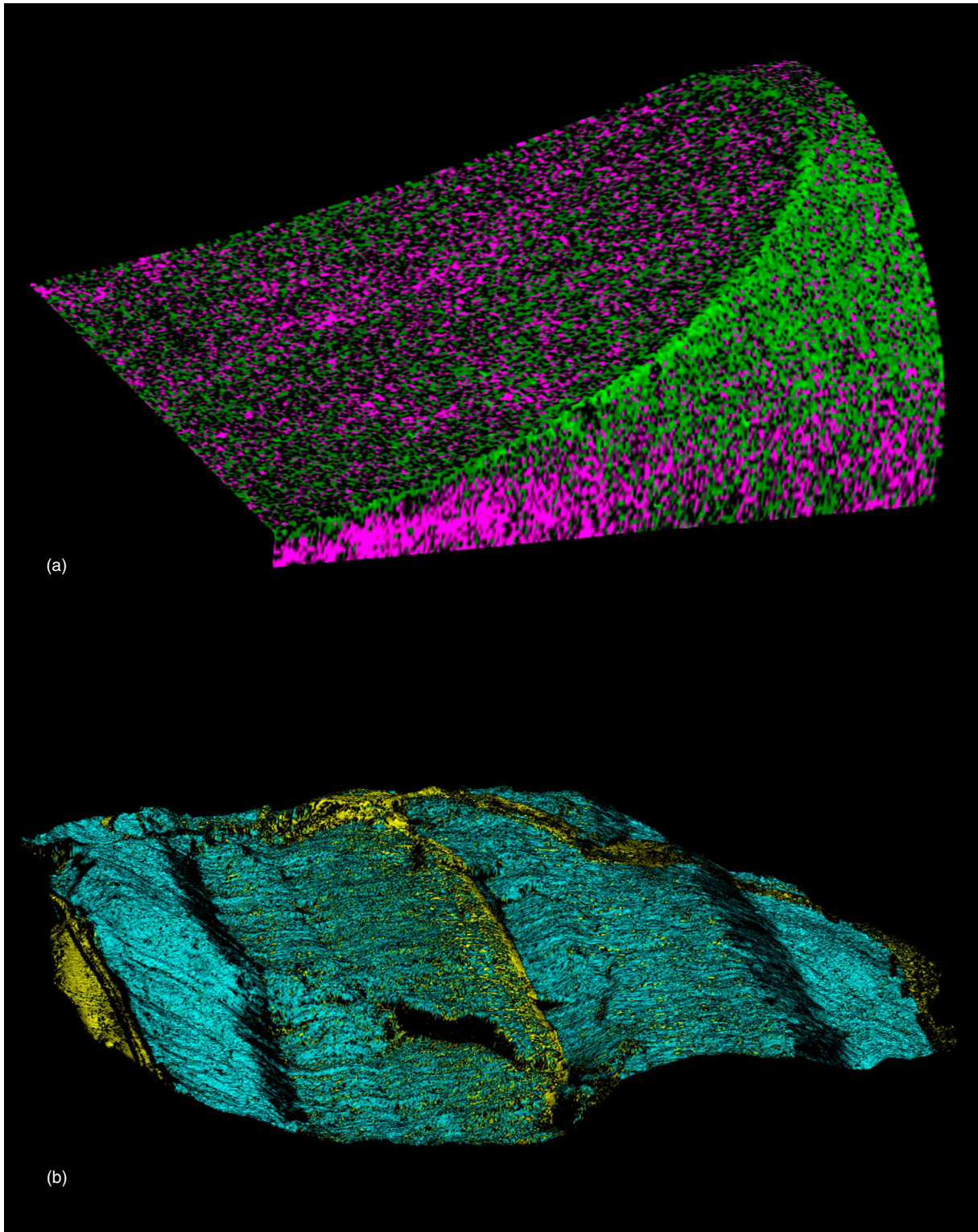

(a) Analysis of a coated flat-head screwdriver bit. The image reveals the distributions of TiN (green) and TiO₂ (magenta). The imaged surface is 8.1 mm wide, 5.1 mm deep and 3.6 mm high.
(b) Quartz-dominated rock (Tiger's Eye). The Raman image shows quartz (cyan) and inorganic carbonates (yellow). The imaged surface is 47 mm wide, 26 mm deep, and 3.0 mm high.

Maintain focus in real time

LiveTrack focus tracking, available on the inVia Qontor, makes it easy to study samples with uneven, curved or rough surfaces. Focus is maintained automatically in real time during data collection and white-light video viewing.

- Keep your view of the sample in focus while you move around under manual control
- Raman-image rough, uneven, and curved surfaces
- Little or no sample preparation is required
- View Raman chemical images in 3D and see both the chemistry and the topography
- No need for time-consuming set up or a pre-scan
- Maintain focus during dynamic measurements, such as sample heating/cooling and during very long measurements when the environmental conditions are varying

LiveTrack technology

To maintain focus, LiveTrack combines precise vertical motion control of the sample stage with new optical technology. It works in both white-light video viewing and Raman acquisition modes, offering significant advantages over alternative techniques.

With LiveTrack, focus is maintained in real-time as the sample:

- is moved under user command (using trackball)
- is scanned during Raman data collection
- expands or contracts (for example because of temperature or humidity changes)

LiveTrack can be offset vertically, enabling Raman data collection to occur at a fixed height below or above the interface being tracked.

LiveTrack saves you time during white-light video viewing

Put your sample on the microscope stage, manually focus using the video viewer, activate LiveTrack, and you are done. LiveTrack will maintain focus as you use the trackball to move the stage around to survey the sample.

This saves you considerable time as manual 'move-focus-move' operations are replaced with just 'move'. You can concentrate on the features on your sample, rather than continual refocusing.

Raman-map rough, uneven, and curved surfaces

With LiveTrack you can acquire Raman data from irregular surfaces. This not only saves time (you no longer need to section, microtome or mill to make flat) but also enables you to study the physical and chemical state at the surface, rather than in the bulk.

As data collection progresses, LiveTrack continuously adjusts the sample height to keep the sample in focus. The resulting data can be displayed as 2D ('top-down') images or as 3D rotatable surfaces which convey not only the chemical structure of your material, but also its topography.

Use with dynamic samples

LiveTrack will keep the sample in focus even if the sample height is changing because of humidity, temperature or creep changes. LiveTrack can work through optical windows so you can, for example, use it to keep focus on a sample in a hot-cold stage during a series of measurements, made as the temperature is changed.

A technology for all samples

LiveTrack can be used with all of Renishaw's Raman image generation techniques.

You can not only study your existing samples in more detail and more efficiently, but you can also analyse a whole new range of uneven, rough, and curved samples. Maintain sub-micrometre focus even on samples that have height variations of many millimetres. Analyse samples that were previously impractical to study, or would have required extensive sample preparation. Generate Raman images and layer these onto 3D views of the sample topography. Manipulate these images in 3D - you choose the view!

Generate high quality Raman images

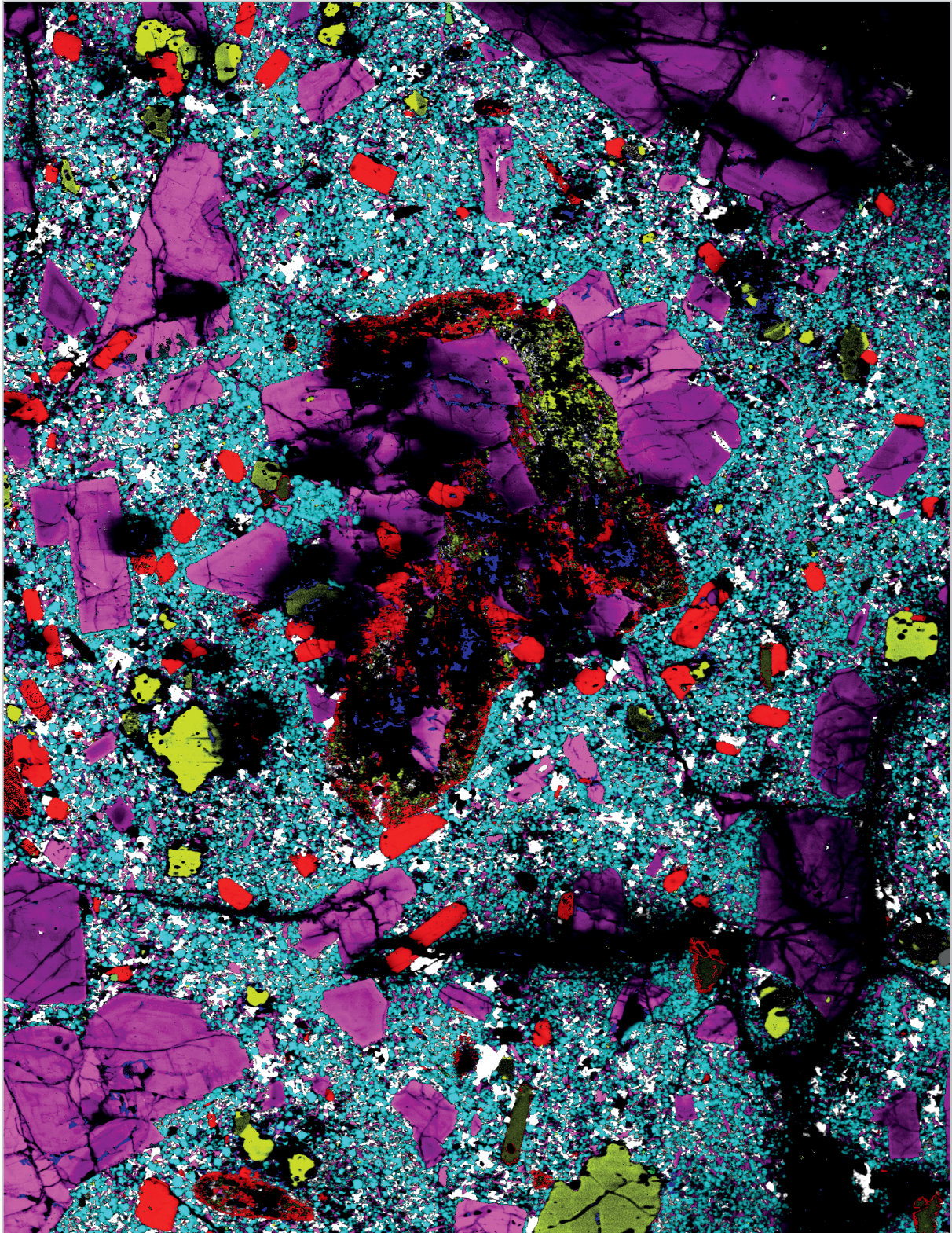

A high definition Raman image of a volcanic rock section from Mount St Helens generated from 2.7 million spectra. The colours indicate the many different minerals present. Rock section courtesy of Dr Claire Horwell and David Damby, University of Durham, UK.

Raman images reveal spatial information about materials and their properties.

Optimal images of your samples

Raman images illustrate the spatial variation of Raman data, and reveal chemical and physical (e.g. stress) information about samples. inVia can generate Raman images from data acquired by mapping (acquiring many complete spectra and processing them to generate images) and by direct imaging of spectral features in a single exposure.

Produce chemical images with the detail you need

inVia supports the broadest range of advanced Raman image generation techniques so that you can study the widest range of samples. Raman analysis is non-contact and non-destructive, and doesn't require dyes or labels, making it suitable for the study of biological samples. Choose the most appropriate technique, or combination of techniques, for your samples.

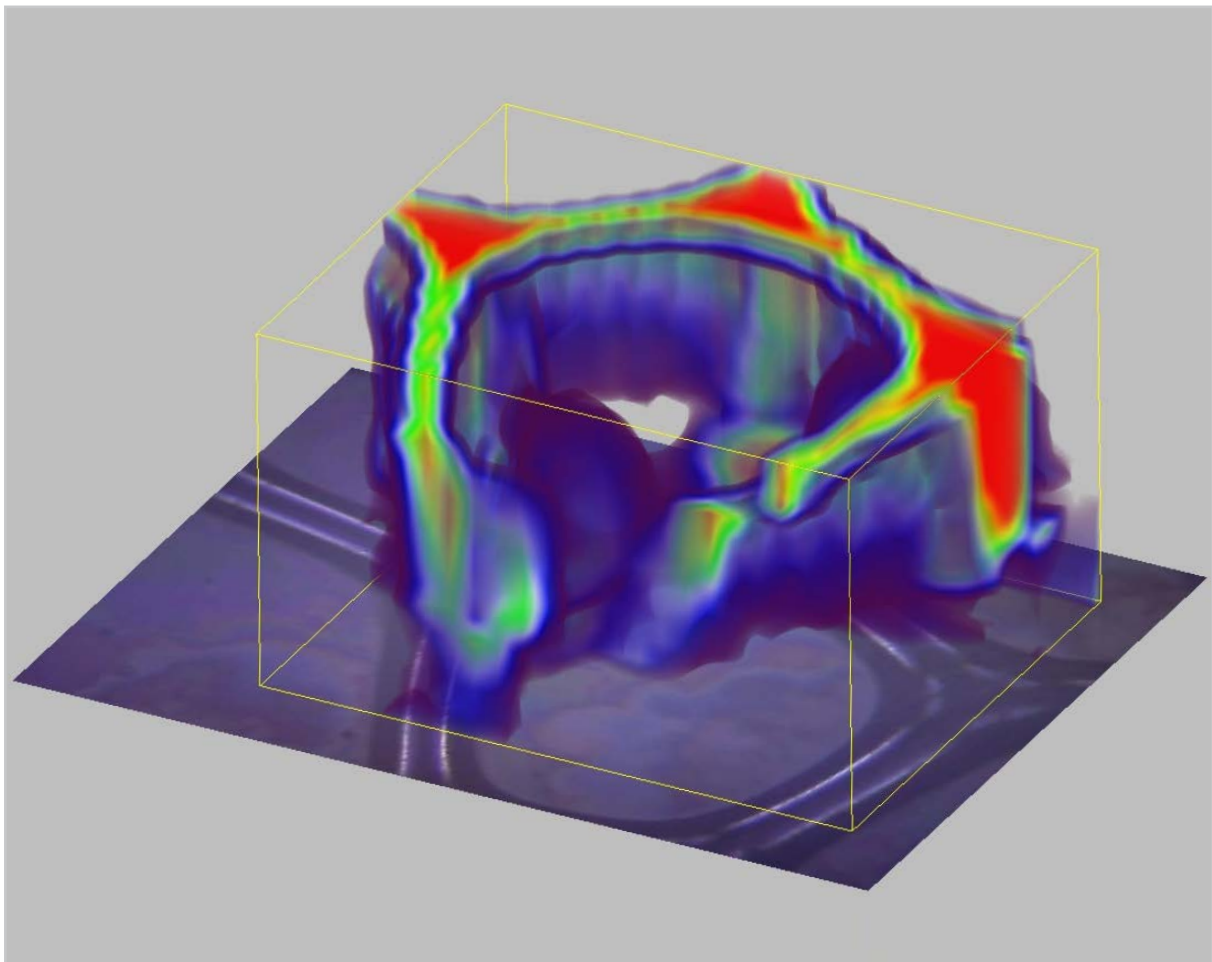

200 μm deep 3D image of a delicate surfactant foam containing air bubbles.

Generate high quality Raman images



Discrete points map; fast, targeted analysis of single particles within a nasal spray droplet. The image reveals the drug and excipient location relative to the white light image.

Point analysis

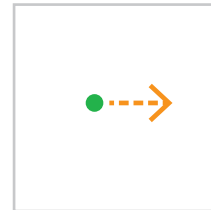

In addition to acquiring information-rich Raman chemical images, inVia can acquire spectra from single points on a sample and display them on a traditional white-light microscope image.

- Providing 1D, 2D and 3D options, point analysis is highly flexible and ideal for single point and irregular array work.
- Ideally suited to the analysis of materials with very weak Raman scattering, where data collection times are long (>10 s).

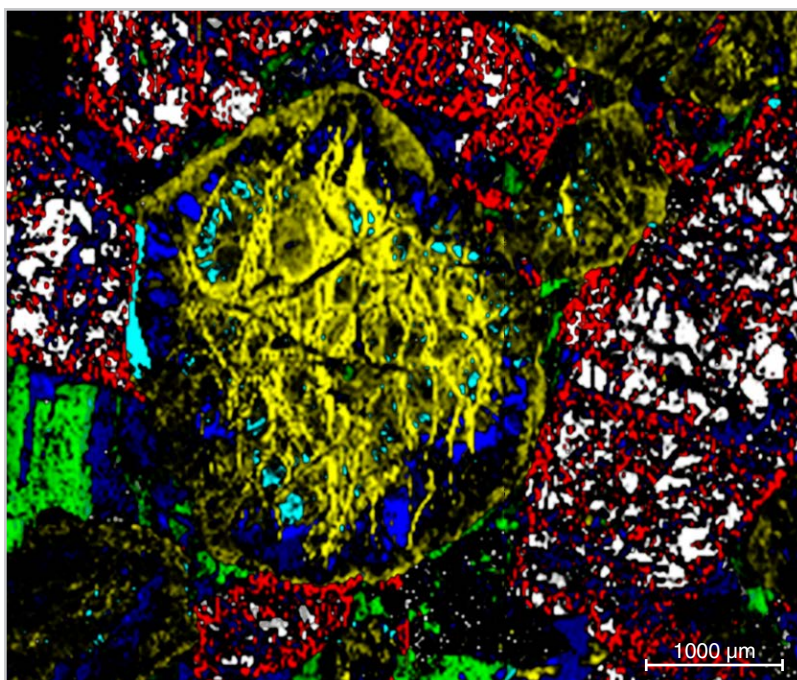

A detailed Raman image of a polished section of igneous rock from Tibet revealing its complex mineral composition. StreamLine was used as it helps prevent transformation of sensitive minerals.

StreamLine™



Uses a line illumination for the rapid generation of 2D (XY) images.

- A line-focused laser minimises power density. This enables the use of higher laser powers without harming sensitive or delicate samples.
- Ideal for revealing very large domains down to 1 μm in size.

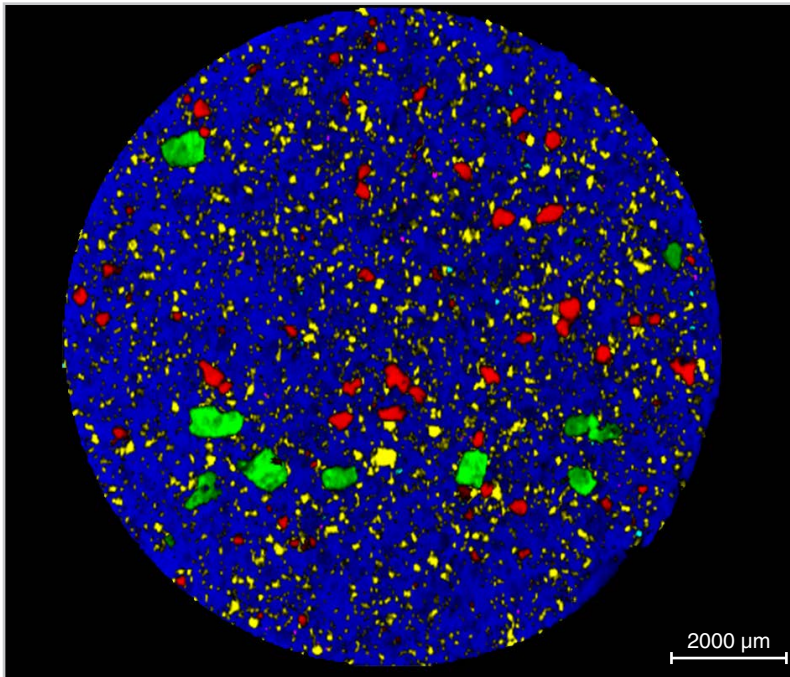

Raman image (generated with StreamLine Slalom) of a pharmaceutical tablet showing the distribution and domain sizes of multiple active ingredients and excipients. Slalom provides complete area coverage, resulting in accurate fraction estimates.

StreamLine Slalom

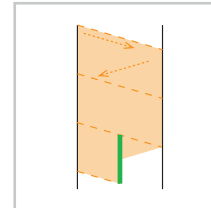

The StreamLine Slalom option uses a novel sample motion in conjunction with line illumination.

- Ensures complete sample coverage, even when using a large step size.
- Use it to survey very large areas quickly and find key regions of interest.

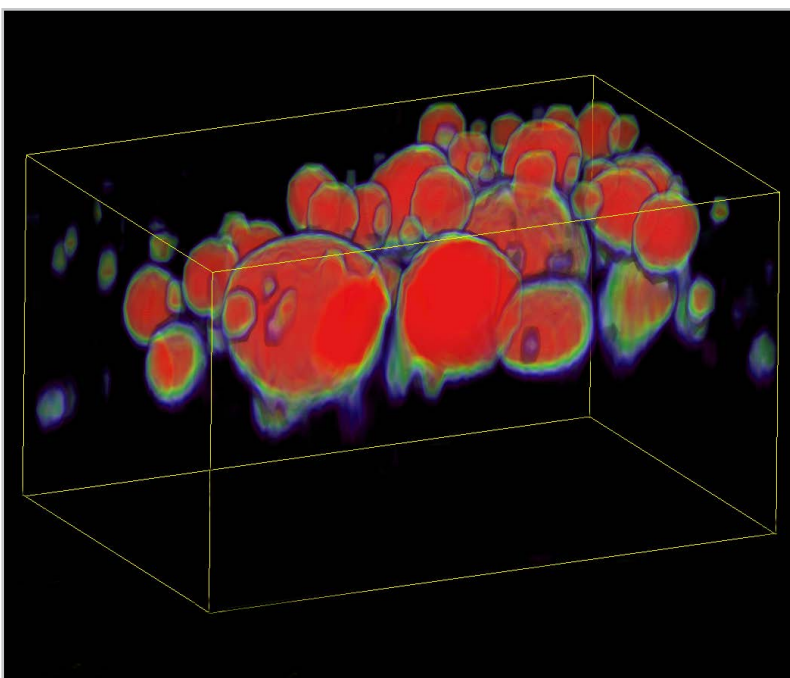

A confocal StreamHR 3D image of cosmetic cream comprising oil in water. The vesicles range in size from 0.4 μm to 7 μm in diameter.

StreamHR™

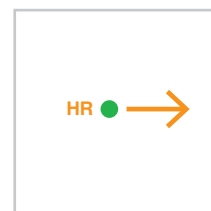

Uses a laser spot for the fast generation of high spatial resolution confocal 2D and 3D images.

- Generates Raman images with pixel sizes down to as low as 100 nm (feature resolution ~250 nm).
- Ideal for 3D images.

Generate high quality Raman images

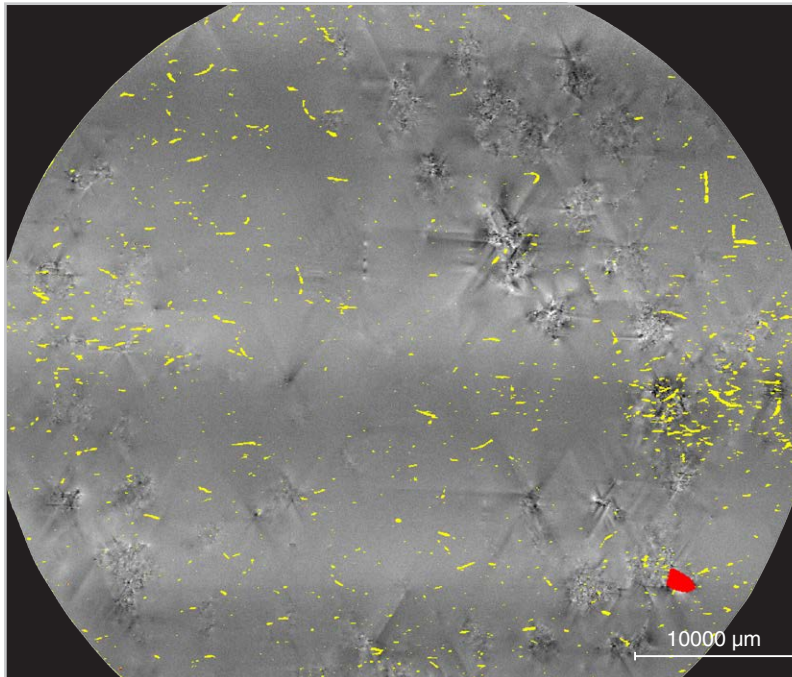

A StreamHR Rapide Raman image of a SiC wafer derived from 900,000 spectra. The image shows stress (grey), defects (yellow), and an inclusion (red).

Rapide



Boosts StreamHR to provide ultra fast Raman data collection.

- Combines fast detector readout and novel constant velocity stage motion for rapid imaging.
- Electron multiplied (EM) detector option enables Raman signal levels to be enhanced when signal and background levels are very low.
- Ideal for 2D and 3D images when speed is essential.

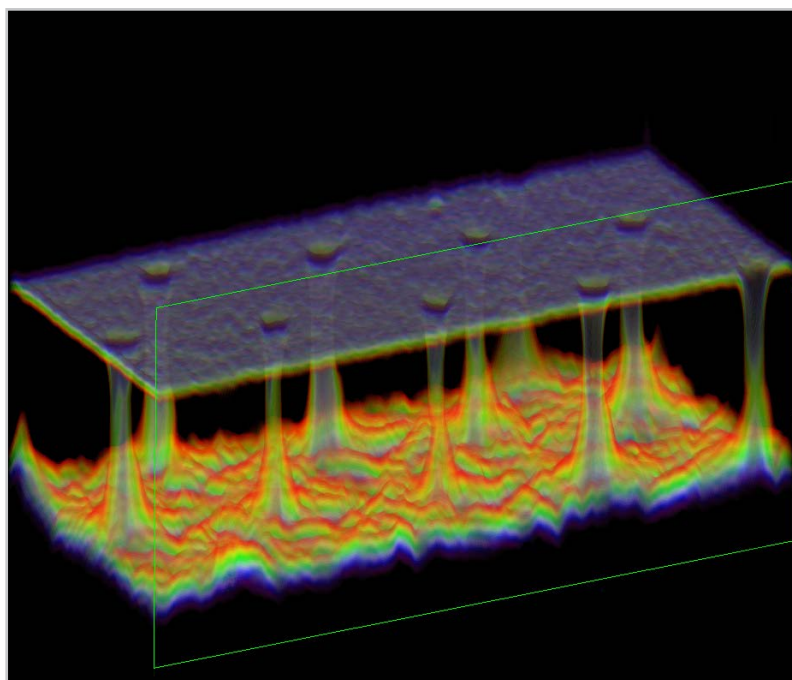

Confocal StreamHR image of an 8 μm thick gallium nitride layer grown epitaxially on a patterned sapphire substrate. The patterning improves layer quality during growth by concentrating dislocations into small regions.

Confocal depth imaging

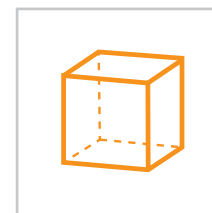

Provides sub-surface confocal Raman information.

- Determine detailed chemical and property information from different depths within suitable samples.
- Use high focality to generate high spatial resolution profiles, slice and volume images.
- Create stunning 2D and 3D images that clearly illustrate your scientific findings.

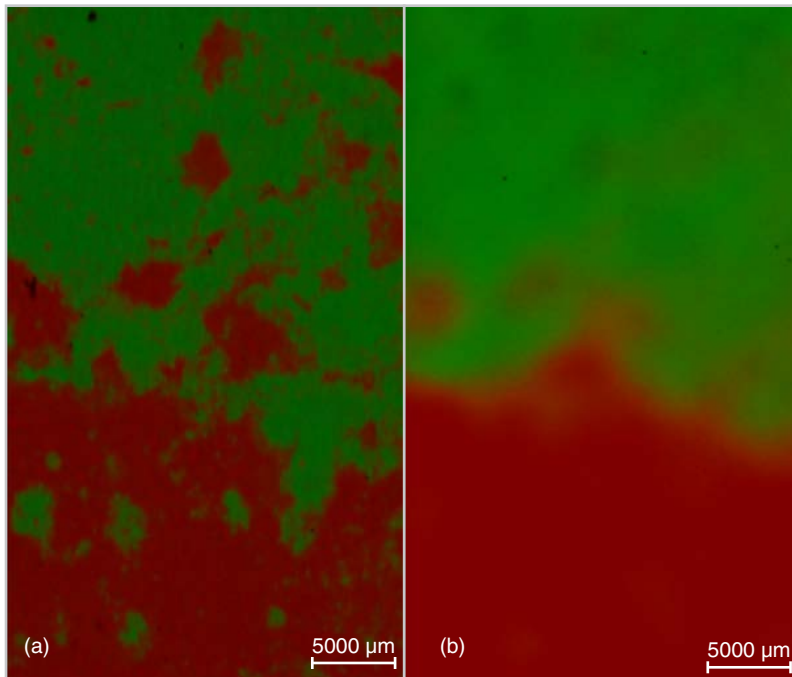

Backscattered and transmission Raman images of a caffeine and acetaminophen powder blend. The backscatter image (a) reveals the surface composition; the transmission image (b) reveals averaged information through the whole depth.

Transmission mapping

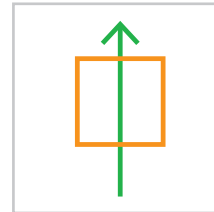

Combines transmitted light collection and sample movement to provide Raman images through the entire sample depth.

- Uses a collimated laser beam for the fast, quantitative analysis of bulk materials, mixtures and blends.
- Ideal for studying blend uniformity, studying samples in containers, monitoring samples with coatings and quantifying large volumes.
- Generate distribution and global average information from very large powder blends.

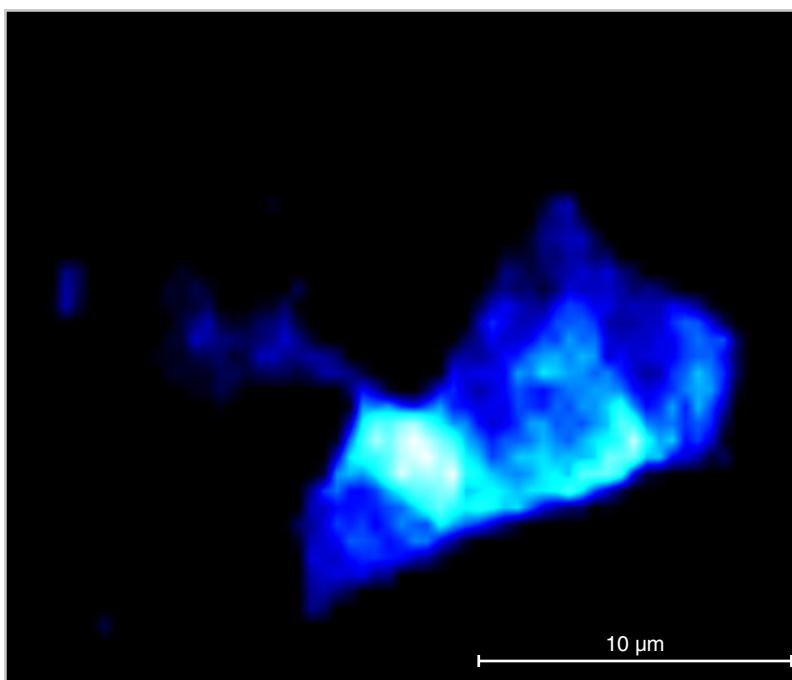

A True Raman Image, acquired in only one minute, reveals a graphene flake.

True Raman Imaging™

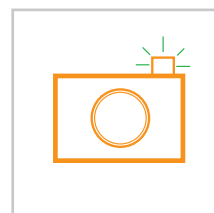

Directly images Raman scattered light from a defocused laser spot to provide a chemical photograph of your sample.

- Uses a filter to rapidly acquire a Raman image from just one Raman band in a single exposure.
- Determines the spatial distribution of chemical species.
- Study the spatial variations of samples that change rapidly with time.

Powerful Raman software

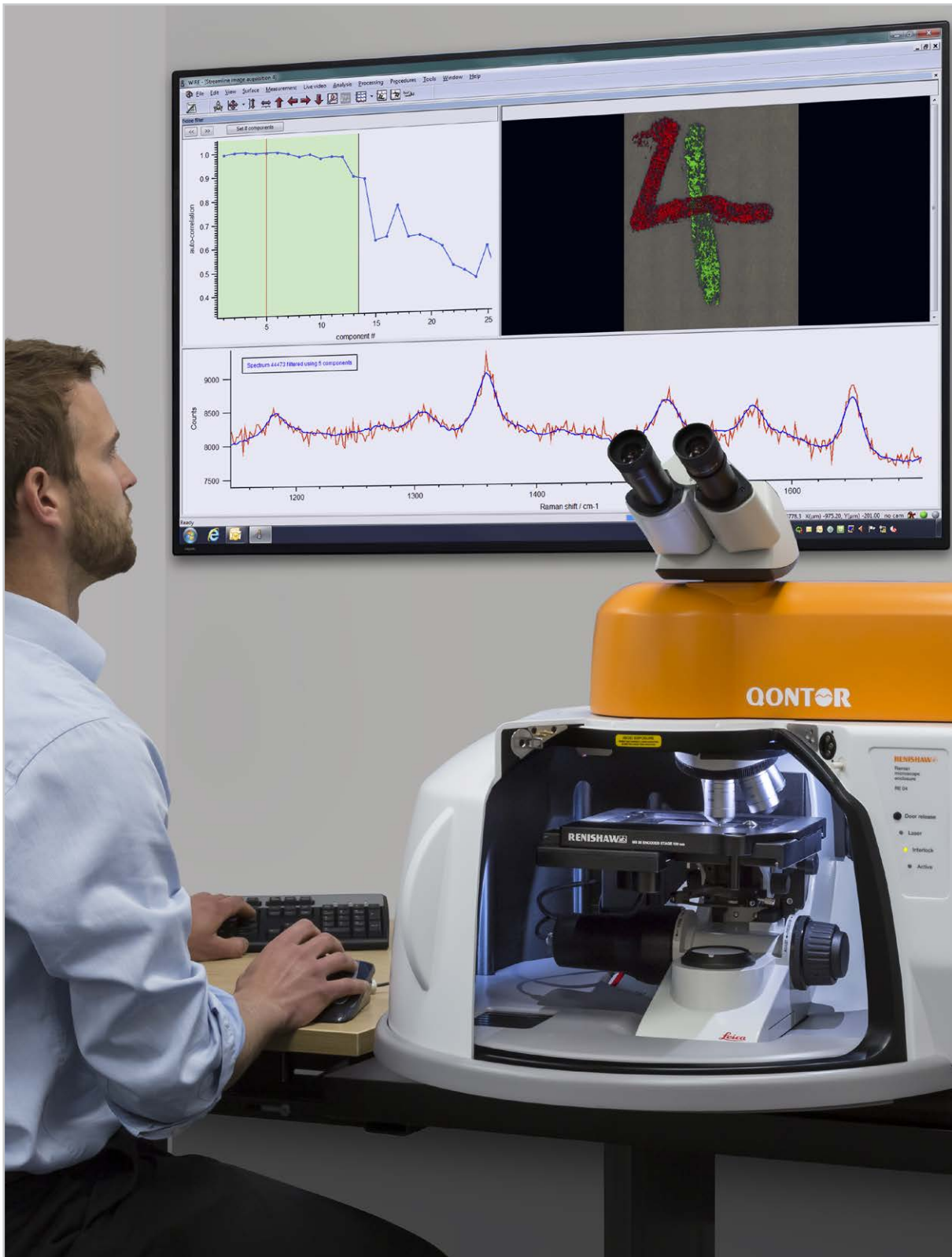

Using the advanced noise removal techniques in Renishaw's WIRE software to analyse ink on a questioned document.

Renishaw's WiRE software, the power behind inVia

WiRE controls the acquisition of spectra and provides dedicated data processing and analysis options, so you can, for example, identify an unknown spectrum, remove its background, or even determine the distribution of particles in megapixel-sized Raman images.

Easy setup

WiRE automates:

- switching of laser wavelength
- Rayleigh filter selection
 - Raman to PL
 - Conventional Stokes to anti-Stokes
 - Standard range to ultra-low wavenumber Eclipse
- selection of diffraction gratings that govern spectral coverage and resolution
- switching between sample viewing and Raman acquisition modes
- microscope control
 - white light intensity
 - aperture stop
 - focus stop
 - objective parcentricity option
 - objective parfocality option
- Automatic alignment of laser position on sample, or manual movement for spatially offset Raman spectroscopy (SORS) measurements

Data processing and analysis

WiRE contains dedicated features for processing and analysing data.

- Fast and targeted removal of cosmic ray features during and after data collection
- Automatic removal of spectral backgrounds
- Enhance data quality using advanced noise removal techniques
- Univariate and multivariate image generation, with supervised and unsupervised analysis options
- Quantify species, domain size, and distribution using particle statistics
- Dynamic generation of Raman images from 2D map data
- Process and analyse 3D data by applying chemometrics to the whole volume

Spectral databases

Renishaw has developed an extensive range of Raman spectral databases for the identification of materials. This simplifies analysis by enabling the automated, computer-aided spectral identification of unknowns.

Databases include inorganic materials and minerals, polymeric, excipient and forensic materials. Other 3rd party libraries can also be used.

Simplified workflow

Save time by storing specific measurement configurations for subsequent access. WiRE enables you to define and execute measurement templates and workflows. These guarantee reproducibility of all parameters, such as laser excitation, laser power, laser quenching and spectral range.

Use WiRE's queuing capability to configure measurements and leave WiRE to run them for you. Export results, spectra and images to other applications.

3D volume viewing

Use Renishaw's 3D volume viewer to review 3D data. With full control over viewing angle and transparency you can present the results clearly.

Empty modelling

Use Renishaw's proprietary empty modelling technique to automatically analyse mixtures and indicate the components present. This can be achieved without any prior sample knowledge.

The inVia range of Raman microscopes

inVia is available in three models to suit your needs; from the flagship inVia Qontor system - with full automation and focus tracking technology - to the entry level inVia Basis system.

	inVia Basis	inVia Reflex	inVia Qontor
Sample viewing			
Stereo viewing (binocular eyepieces)	O	●	●
Memorised and automatic post collection viewing	-	●	●
Software microscope control	-	●	●
Automatic white light/Raman switching	-	●	●
Automatic white light saving with data	-	●	●
Combined white light and laser video viewing	-	●	●
White light auto-focus (LiveTrack)	-	-	●
Raman data collection			
Automated measurement queuing	●	●	●
Automatic focus tracking (LiveTrack)	-	-	●
Alignment and performance checking			
Internal neon wavelength calibration source	-	●	●
Internal reference standards for auto-callibration	-	●	●
Automated Raman calibration correction (quick calibration)	●	●	●
Laser auto-align	●	●	●
Raman signal auto-align	●	●	●
Performance health check	-	●	●

Key

- not available
- O option
- included

inVia Qontor

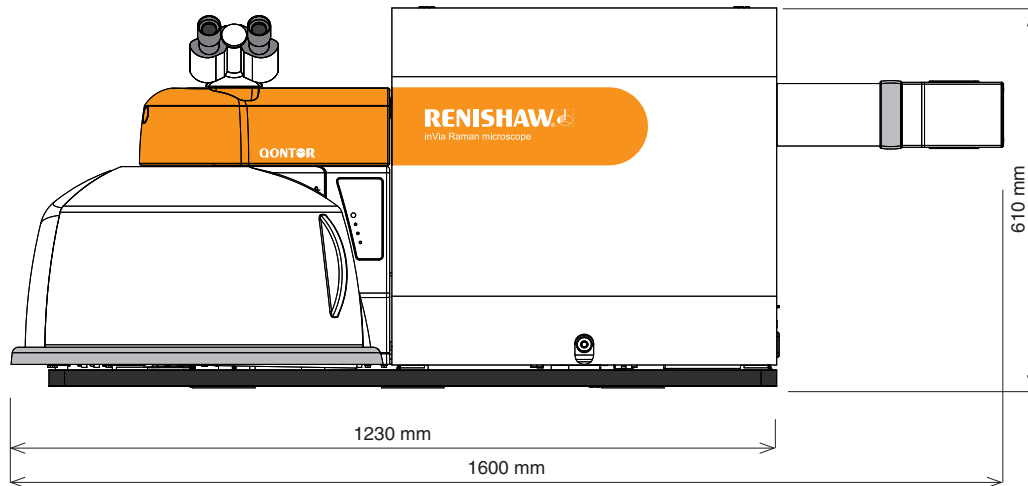

Shown with optional microscope enclosure

inVia Reflex

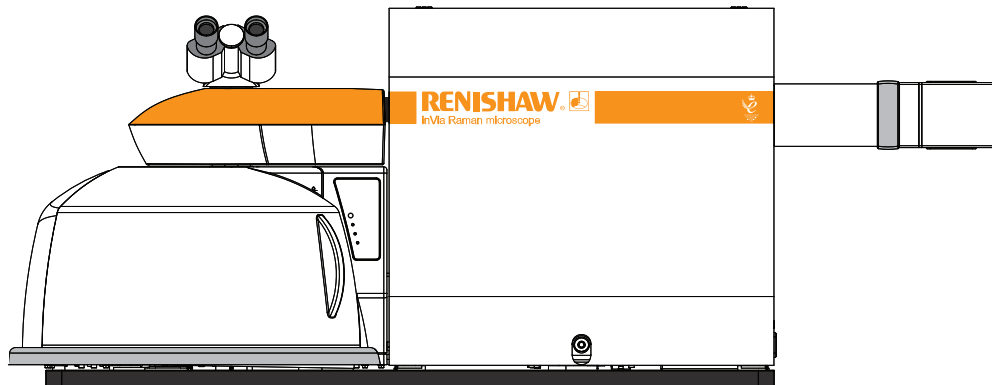

Shown with optional microscope enclosure

inVia Basis

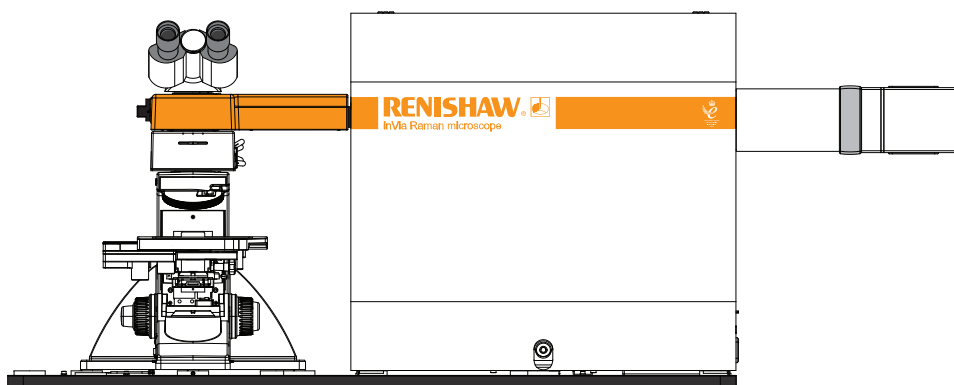

inVia general specifications

Wavelength range	200 nm to 2200 nm	
Lasers supported	From 229 nm to 1064 nm	
Spectral resolution	0.3 cm ⁻¹ (FWHM)	Highest typically necessary: 1 cm ⁻¹
Stability	< ±0.01 cm ⁻¹	Variation in the centre frequency of curve-fitted Si 520 cm ⁻¹ band, following repeat measurements. Achieved using a spectral resolution of 1 cm ⁻¹ or higher
Low wavenumber cut-off	5 cm ⁻¹	Lowest typically necessary: 100 cm ⁻¹
High wavenumber cut-off	30,000 cm ⁻¹	Standard: 4,000 cm ⁻¹
Spatial resolution (lateral)	0.25 µm	Standard: 1 µm
Spatial resolution (axial)	< 1 µm	Standard: < 2 µm. Dependent on objective and laser
Detector size (standard)	1024 pixel × 256 pixel	Other options available
Detector operating temperature	-70 °C	
Rayleigh filters supported	Unlimited	Up to 4 filter sets in automated mount. Unlimited additional filter sets supported by user-switchable accurately-locating kinematic mounts
Number of lasers supported	Unlimited	1 as standard. Additional lasers beyond 4 require mounting on an optical table
Windows PC controlled	Latest specification Windows® PC	Includes PC workstation, monitor, keyboard and trackball
Supply voltage	110 V AC to 240 V AC +10% -15%	
Supply frequency	50 Hz or 60 Hz	
Typical power consumption (spectrometer)	150 W	
Depth (dual-laser systems)	930 mm	Dual laser baseplate
Depth (triple-laser systems)	1116 mm	Triple laser baseplate
Typical mass, excluding lasers	90 kg	

System performance depends on individual configuration and options. Due to the range of options and configurations of the inVia this information is given as a guide to performance. For more detailed and specific performance and specifications please contact your local Renishaw representative.

Laser safety

Class 3B laser product

- Standard system for operation with laser wavelengths from 320 nm to 1064 nm



Class 1 laser product

- This option is available (subject to system configuration) for systems operating with laser wavelengths in the range 320 nm to 1064 nm



Class 4 DUV laser product

- System with at least one path configured for operation at laser wavelengths in the range 180 nm to 315 nm. (Dependent on configuration, these systems may also operate at laser wavelengths from 320 nm to 1064 nm)



Class 4 Vis/NIR laser product

- Systems operating with Class 4 (visible) lasers can be provided as a custom solution tailored to meet customers' requirements subject to the laser power(s) not compromising the integrity or function of the system.

About Renishaw

Renishaw is an established world leader in engineering technologies, with a strong history of innovation in product development and manufacturing. Since its formation in 1973, the company has supplied leading-edge products that increase process productivity, improve product quality and deliver cost-effective automation solutions.

A worldwide network of subsidiary companies and distributors provides exceptional service and support for its customers.

Products include:

- Additive manufacturing and vacuum casting technologies for design, prototyping, and production applications
- Dental CAD/CAM scanning systems and supply of dental structures
- Encoder systems for high-accuracy linear, angle and rotary position feedback
- Fixturing for CMMs (co-ordinate measuring machines) and gauging systems
- Gauging systems for comparative measurement of machined parts
- High-speed laser measurement and surveying systems for use in extreme environments
- Laser and ballbar systems for performance measurement and calibration of machines
- Medical devices for neurosurgical applications
- Probe systems and software for job set-up, tool setting and inspection on CNC machine tools
- Raman spectroscopy systems for non-destructive material analysis
- Sensor systems and software for measurement on CMMs
- Styli for CMM and machine tool probe applications

For worldwide contact details, visit www.renishaw.com/contact



RENISHAW HAS MADE CONSIDERABLE EFFORTS TO ENSURE THE CONTENT OF THIS DOCUMENT IS CORRECT AT THE DATE OF PUBLICATION BUT MAKES NO WARRANTIES OR REPRESENTATIONS REGARDING THE CONTENT. RENISHAW EXCLUDES LIABILITY, HOWSOEVER ARISING, FOR ANY INACCURACIES IN THIS DOCUMENT.

© 2016 Renishaw plc. All rights reserved.

Renishaw reserves the right to change specifications without notice.

RENISHAW, the probe symbol used in the RENISHAW logo, and Qontor are registered trade marks of Renishaw plc in the United Kingdom and other countries. apply innovation and names and designations of other Renishaw products and technologies are trade marks of Renishaw plc or its subsidiaries.

All other brand names and product names used in this document are trade names, trade marks or registered trade marks of their respective owners.



L - 9836 - 4969 - 02

Part no.: L-9836-4969-02-B
Issued: 08.2016