

Atomic Absorption Spectrophotometer

# AA-6200



# AA-6200

## Atomic Absorption Spectrophotometer



As analyses have diversified in recent years, instruments have been engineered with more diverse functionality and become more sophisticated. This sophistication often makes the instruments difficult to master. Despite these developments, atomic absorption spectrophotometers must be simple and easy for analysts to operate, allowing them to use the instrument instantly whenever needed, with complete ease.

- **Minimal delay before starting analysis**
- **Easy-to-understand operation**
- **Large enough to provide immediate access to operable sites**

In addition, it is important that the instrument be affordable.

The Shimadzu AA-6200 atomic absorption spectrophotometer completely addresses these concerns. The Wizard function has been designed so that even inexperienced AA users can easily operate the instrument.

In addition, despite its compact, easy-to-handle design, the AA-6200 is loaded with Shimadzu technology to provide excellent performance for a variety of applications.

# A Compact Atomic Absorption Spectrophotometer Created from Shimadzu's Double-Beam Technology

## **PC Software Fully Supports the Analysis Process**

---

The Windows-compatible software is loaded with functions that strongly support the analysis process for everyone, from those unfamiliar with atomic absorption analysis to experts.

## **Wizard Function**

---

The software wizard guides the user through the parameter setup procedure, so even those unfamiliar with atomic absorption analysis can easily set the parameters and start measurements immediately.

It eliminates complicated operations that are commonly experienced with PC-controlled instruments.

## **User-Friendly, All-in-One Operation Window**

---

Perform everything from editing sample schedules and performing measurements to checking the results and creating summary reports, all from the main window.

## **QA/QC Functions Provided as Standard**

---

Numerous QA/QC functions, including checks of calibration curve correlation coefficients and recover rates, ensure reliable measurement results.

## **Double-Beam Optical System Improves the S/N Ratio**

---

Long-term baseline stability is indispensable for flame analysis. Our high-performance double-beam optical system provides a stable baseline.

It is designed to minimize lamp energy loss, so the S/N ratio is significantly improved in comparison with conventional double-beam AA spectrophotometers. In addition, it allows users to perform background correction via the deuterium lamp method, the most sensitive correction method available.

## **Significant Power from a Small Body**

---

Despite its incredibly compact size, the AA-6200 delivers unexpectedly powerful performance.

## **Affordable, yet Sophisticated**

---

This instrument can naturally perform routine analyses, but it is also loaded with a number of functions on par with those offered by high-end models. Select these functions to suit specific requirements, from scheduled analyses to analyses with complicated procedures.

# The Wizard Function Simplifies Operations with Windows

The Wizard function guides you through all analysis setting procedures, including instrument setup and measurement parameter setup.

Simply follow the onscreen instructions in each Wizard window. When finished, click [Next >] to proceed to the next window. The figure on the right shows the element selection window, where you can select multiple elements. Clicking [Next >] guides you to ...



... the editing window for calibration curve parameters and sample preparation conditions.

Select the element to edit, and click [Edit...] to display the next window.

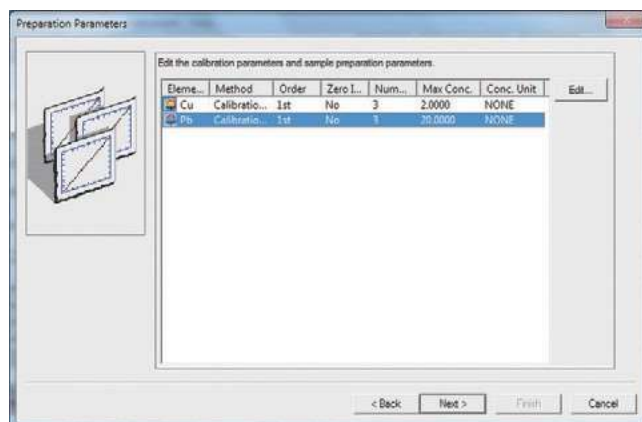

Here, you can set the standard sample concentration, the calibration curve conditions, and the conditions applied if the autosampler is to be used.

Click [OK] to return to the previous window.

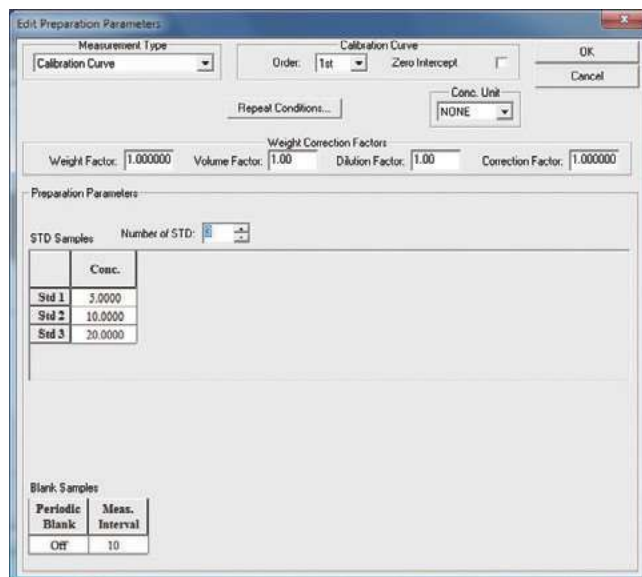

When the conditions have been set, establish the transmission connection between the instrument and PC.  
Click [Next >] to proceed to the next window.

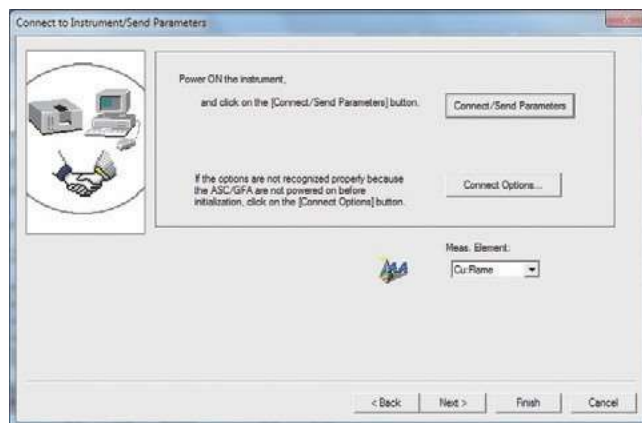

The monochromator setup window is displayed.  
The analytical wavelength and lamp current value for the element to be measured are read in automatically.  
Follow the Wizard instructions to configure the instrument settings, including those for line searches and lamp positioning in order to make full use of the lamp energy.  
To warm up the hollow cathode lamp for the element for the next analysis, click [Warmup Lamp...].  
When the monochromator settings are finished, click [Next >] to proceed to the next window.

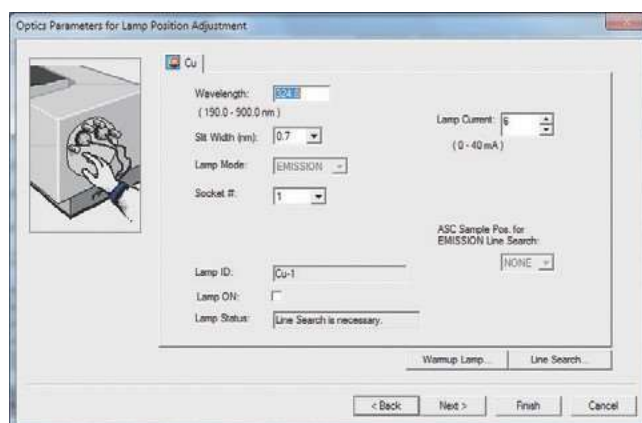

The atomizer setup window is displayed.  
While observing the real-time signal, manually set the fuel gas flow rate and the supporting gas flow rate.  
When all the settings are finished, click [Finish].  
The Wizard will end, and the software will open the measurement window. The sample can now be prepared and the measurements started.

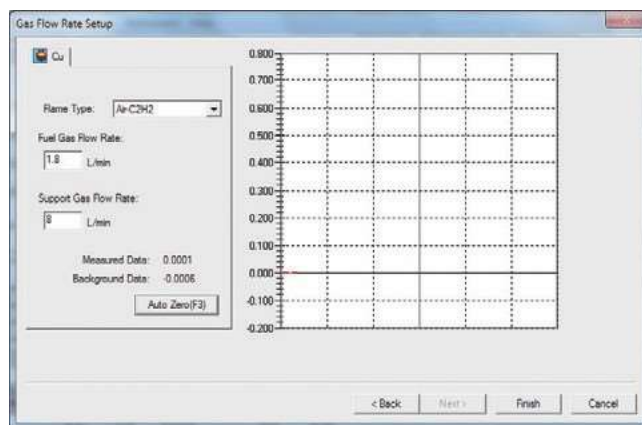

# User-Friendly, All-in-One Operation Window

## Real-Time Signal Monitor Function, Large Enough to See Easily

The real-time signal is monitored with both digital and graphical displays.

### Signal Profile Display, Always Visible

Displays data for the last four measurements. All the signals are recorded, and can be redisplayed at any time. The signals can also be overlapped.

### Calibration Curve Display Pane for Visually Determining Sample Concentrations During Measurements

Displays the calibration curve in use during the analysis. The concentration of an unknown sample being measured can be intuitively determined.

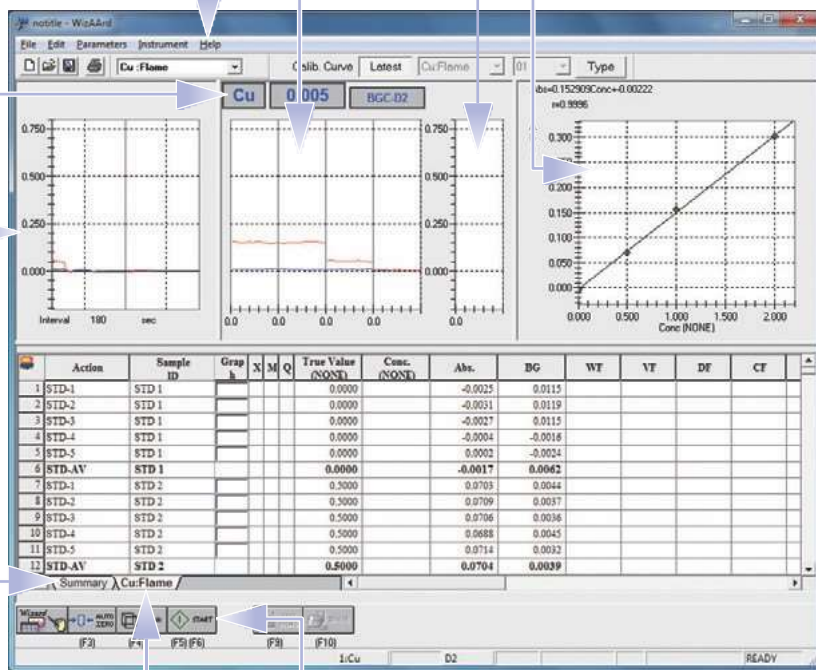

### One-Click Measurement Start Button

When the measurement sequence is ready, click [START] to start the analysis.

### MRT\* Worksheet for Checking Everything at a Glance

The MRT worksheet lists a number of values in a single pane. These values include the sample ID, the absorbance, the background signal (BKG), the concentration obtained from the calibration curve, and the actual sample concentration computed from the correction calculation.

Click on the element tabs to check the information for each element, even during measurement.

### One-Click Summary Reports for the Analysis Results

Click on the tab to display a summary report.

A list of element concentrations for each sample ID (sample name) is instantly displayed with respect to the results obtained, and can be used "as is" for reporting.

\*MRT: Measured Result Table

## Help Function with Electronic Instruction Manual

Click [Help] on the menu bar and type keywords to search for explanations related to operational methods and parameter settings.

The information you need can be found easily and instantly, more conveniently than with paper instruction manuals.

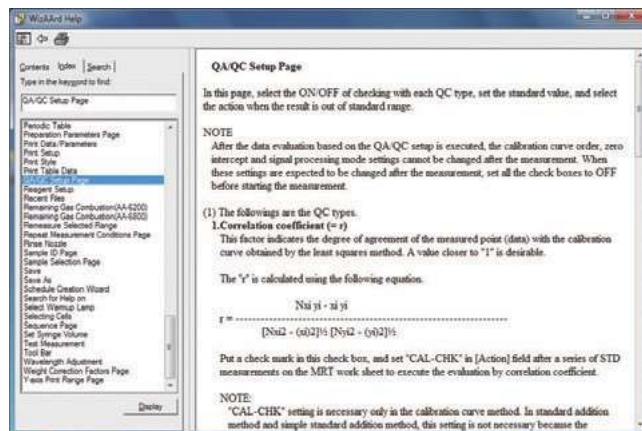

## Advanced Data Processing QA/QC Functions Provided as Standard

- The QA/QC sequence can be checked in the MRT worksheet, just like the ordinary sequence.
- You can select what to do if the measured values are nonstandard. ([Stop Measurement] or [Mark and Continue])

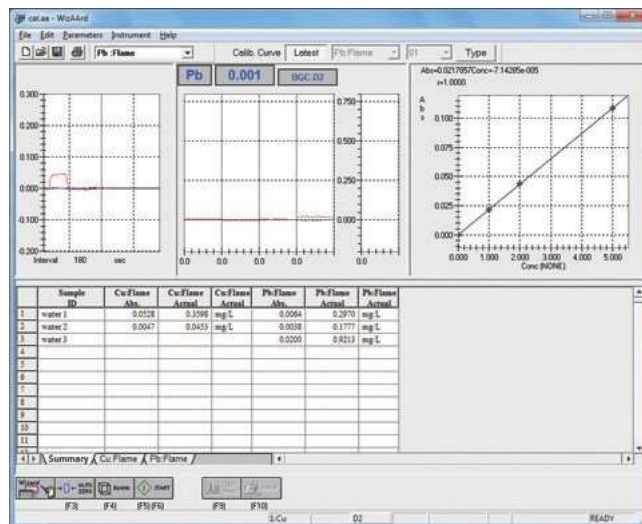
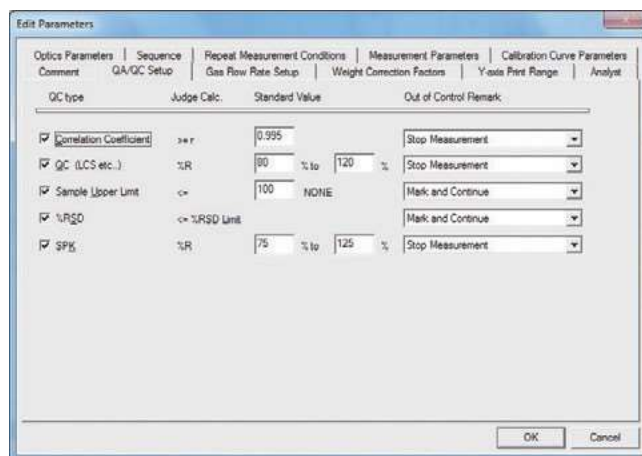

# High-Performance Double-Beam Photometric System

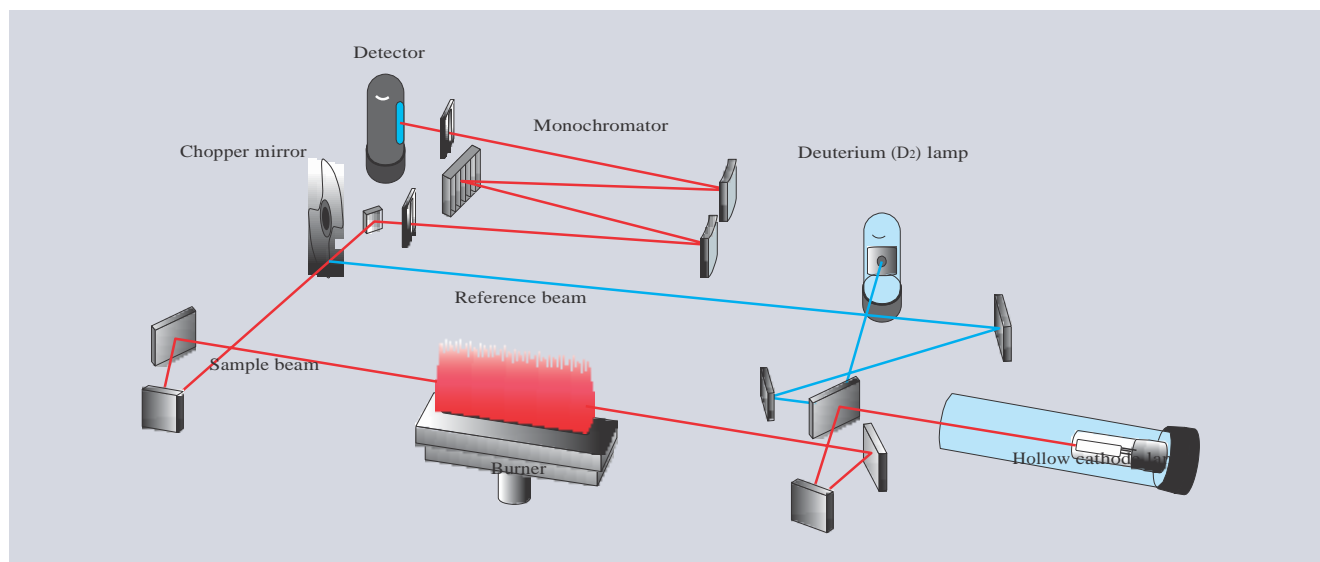

## Superior Baseline Stability

The double-beam photometric system of the AA-6200 compares the sample beam and reference beam in order to automatically remove any fluctuations in light energy from the light source.

This ensures stable analysis results even during long-term continuous analysis. (See Fig. 3.)

## An Optical System Built with Durability in Mind

The optical system of the AA-6200 is completely covered. This design ensures ample durability, even in the acidic atmosphere of a laboratory. Care has been taken to prevent degradation of the mirror and other components, and to minimize energy loss for an extended period, enabling measurements with a good S/N ratio.

## New System Improves the S/N Ratio

The double-beam optical system utilizes a chopper mirror, which minimizes loss of light energy from the light source. The S/N ratio is significantly improved in comparison with conventional optical systems utilizing a beam splitter and beam combiner, thus enabling high-sensitivity analysis. A brushless motor is used for the chopper mirror rotation, extending the operating life.

## The Deuterium Lamp Method—The Most Sensitive Background Correction Method

The deuterium lamp method, the most sensitive of all background correction methods, is provided as standard. This enables highly sensitive and accurate correction, and can be used with ease in almost any sample analysis.

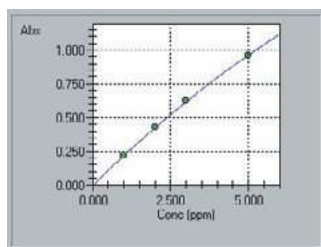

(Fig. 1)

Fig. 1 shows a calibration curve created by measuring a standard Cu solution. A high-sensitivity nebulizer is provided as standard, enabling high-sensitivity analysis.

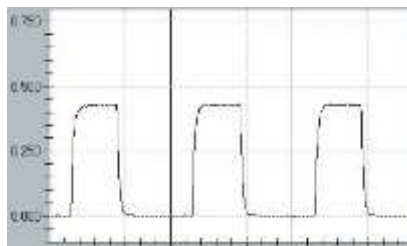

(Fig. 2)

Fig. 2 is the signal profile from the measurement of a 2-ppm standard Cu sample. Low-noise, stable sensitivity is obtained.

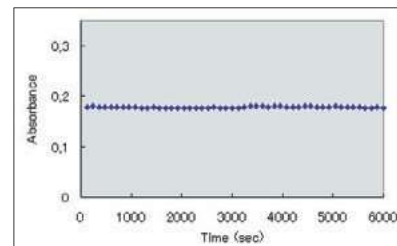

(Fig. 3)

The data in Fig. 3 shows the change in sensitivity when a standard Cr sample is sprayed continuously for 100 minutes. Each point in the figure shows the average value for 10 measurement cycles. As shown, excellent stability is achieved even over a long period of use. The average CV is 0.5 % max.



# Special Accessories

## ASC-6100F Autosampler (P/N: 206-50100-30)

Connect this autosampler to the AA-6200 to enable continuous measurements of up to 60 samples per element.

This saves on labor for routine analyses.

Control : Communication control with the AA via RS-232C  
 Functions : Zero-point detection, auto rinse, self-diagnosis, random access

Number of reagent/sample positions : 8 for reagents; 60 for samples  
 Volume : 40 mL for reagent vials; 16 mL for sample test tubes  
 Cleaning bottle : 2 L



## HVG-1 Hydride Vapor Generator (P/N: 206-17143-XX)

In environmental standards, the hydride generation method is prescribed as a measurement method for As, Se, and Sb.

- In conjunction with the AA-6200, this unit provides quick, high-accuracy quantitation of elements such as As, Se, Sb, and Hg at low ppb levels.
- In conjunction with the ASC-6100F autosampler, this unit provides automatic continuous analysis of up to 60 samples.

### ■ Main Standard Components

HVG-1 unit  
 Absorption cell (P/N: 206-77607)  
 Reagent bottle (P/N: 206-58792-40/-42)  
 Gas hose  
 Drain tube

Note: Requires a "Nozzle ASSY, HVG" (P/N: 206-67563) for operation in conjunction with the ASC-6100F. Please order this separately.

Measurement method : Continuous flow  
 Sample consumption : 0 to 7 mL/min, variable  
 Reagent consumption : 0 to 2.5 mL/min, variable  
 Atomizer : Heated absorption cell (heated by Air-C<sub>2</sub>H<sub>2</sub> flame in standard system)  
 Carrier gas : Ar; pressure: 0.35 MPa; consumption: 70 mL/min  
 Power requirements : 100, 120, 220, 230, or 240 V AC, 35 VA, 50/60 Hz

Dimensions and weight : W340 × D220 × H200 mm; approx. 9 kg



## SARF-16C Atomic Muffle Furnace (Electric Cell Heater) (P/N: 208-97249)

- The flame heating method provides even higher sensitivity. The special furnace unit enables measurements via the hydride generation method.
- The temperature controller optimally controls the quartz cell temperature.
- Provides good temperature reproducibility, prevents damage to the cell from overheating, and extends the cell's operating life.

Note: Requires an attachment adaptor set (P/N: 206-50794-91) Please order this separately.

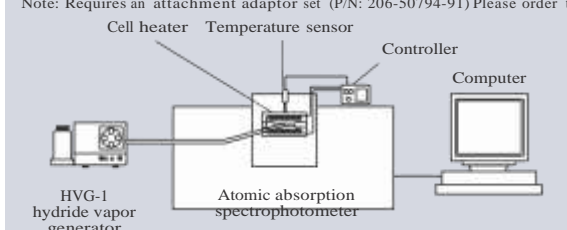

### • Furnace

Dimensions : W170 × D110 × H110 mm  
 I.D. : 25 dia. × 170 mm  
 Heater : PYROMAX DS

### • Controller

Operating temperature range : Room temperature to 1100 °C  
 Temperature control range : ±2.5 °C  
 Load capacity : 1000 W max.  
 Power requirements : 100 V AC, 400 VA, 50/60 Hz



## MVU-1A Mercury Vaporizer (P/N: 206-58780-XX)

This mercury vaporizer is for cold vapor atomic absorption spectroscopy. It improves the sensitivity and simplifies measurements in water quality analyses.

Vaporization method : Reduction vaporization with a reducing agent  
 Measurement method : Recirculation  
 Flow cell : Optical path length of 100 mm (with quartz window)  
 Sample volume : 250 mL max.

Exhaust contamination prevention : Adsorption trapping in mercury trap bottle  
 Dimensions and weight : W310 × D357 × H288 mm; approx. 10 kg

### ■ Main Standard Components Qty

MVU-1A unit : 1  
 Reaction vial (P/N: 200-93018-01) : 5  
 Reaction vial lid (P/N: 204-21989) : 2

Note: Please order the following items separately.  
 Gas flow cell (P/N: 201-98687)

Stirrer tip (P/N: 046-00617-06) : 10  
Mercury lamp bottle (P/N: 200-3877-43)

Holder for gas flow cell (P/N: 202-35867)  
Hg hollow cathode lamp (P/N: 200-38422-28)



## AA-6200

Atomic Absorption Spectrophotometer

# Optional Accessories and Related Products

## High-Temperature Burner Head (P/N: 206-50300-91)

- Made of titanium, with a 5-cm slot for N<sub>2</sub>O-C<sub>2</sub>H<sub>2</sub> flame
- Extremely corrosion-resistant
- Can also be used for Air-C<sub>2</sub>H<sub>2</sub> flame



## Hollow Cathode Lamps (P/N: 200-38422-XX)

This is utilized when background correction is not performed, or when the deuterium (D<sub>2</sub>) lamp method is employed.

### ● Single-element lamps (L-233 Series)

Ag, Al, As, Au, B, Ba, Be, Bi, Ca, Cd, Co, Cr, Cs, Cu, Dy, Er, Eu, Fe, Ga, Gd, Ge, Hf, Hg, Ho, In, Ir, K, La, Li, Lu, Mg, Mn, Mo, Na, Nb, Nd, Ni, Os, Pb, Pd, Pr, Pt, Rb, Re, Rh, Ru, Sb, Sc, Se, Si, Sm, Sn, Sr, Ta, Tb, Te, Ti, Tl, Tm, V, W, Y, Yb, Zn, Zr

### ● Composite lamps (L-733 series)

Ca-Mg, Na-K, Si-Al, Fe-Ni, Ba-Sr

## Air Compressor (P/N: 208-91753-91)

Type : Oil free  
 Working pressure : 0.59 MPa  
 Return pressure : 0.39 MPa  
 Tank capacity : 12 L

Discharged air quantity : 25 L/min (50 Hz)  
 31 L/min (60 Hz)

Power requirements : 100 V AC, 4 A, 50/60 Hz  
 Noise level : 58 dB (A)/1.5 m  
 Dimensions : W415 × D267 × H514 mm  
 Weight : 16 kg

Note: Includes mist separator.



## Low-Noise Air Compressor (P/N: 208-91750-33)

Type : Oiling  
 Working pressure : 0.7 MPa  
 Return pressure : 0.5 MPa  
 Tank capacity : 12 L

Discharged air quantity : 50 L/min (50 Hz)  
 60 L/min (60 Hz)

Power requirements : 230 V AC, 5.7 A, 50/60 Hz  
 Noise level : 45 dB (A)/1 m  
 Dimensions : W380 × D380 × H480 mm  
 Weight : 26 kg

Note: Includes mist separator.



## Mist Separator Kit (P/N: 206-52458-91)

This kit completely removes oil and moisture mixed into the air supplied from the air compressor. Attach this if you are using an air compressor other than the Shimadzu model noted above.

Dimensions : W110 × D201 × H252 mm  
 Weight : Approx. 1 kg

## Precision Gas Pressure Regulators

Commercially available C<sub>2</sub>H<sub>2</sub> gas regulators are designed for welding, making them inappropriate for atomic absorption analysis in terms of safety and stability.

The Shimadzu precision gas pressure regulators have a two-stage design featuring a safety needle valve and a check valve. The MAF-85S model is equipped with a radiator fin type heat exchanger that does not use a heater, so it operates safely.

Model	Use	P/N	Screw Specifications for Attachment to the Cylinder
MAF-85S	For dinitrogen oxide	040-72019-11	W22-14RH
YR-71	For acetylene	040-72020-01	AC2 mounting bracket

# Optional Accessories and Related Products

# Specifications

## AA-6200

Photometric system	Double-beam system (using chopper mirror)	Burner position	Rotational manual adjustment; fixed up/down and back/forward (adjustment not required)
Monochromator	Aberration-corrected Czerny-Turner monochromator	Gas controller	Manual flow rate setting Automatic sequential switching to N <sub>2</sub> O:C <sub>2</sub> H <sub>2</sub> flame
Diffraction grating	Holographic grating	Safety measures	Pressure monitor for preventing flashback Flame monitor for detecting flame burnout Mechanism for preventing incorrect use of the burner Mechanism for extinguishing flame for safety during a power outage
Wavelength range	190 to 900 nm	Ignition method	Automatic ignition via the pilot flame
Slit width	0.2 nm, 0.7 nm; two-stage manual switching	PC control	Control system operating in an English Windows 7/XP environment
Wavelength drive	Automatic; automatic wavelength setting via the line search function	Dimensions and weight	W690 × D425 × H370 mm; 38 kg
Background correction	Deuterium lamp method	Power requirements	100 V AC ± 10 %, 50/60 Hz, 300 VA (Uses an external voltage transformer.)
Number of lamps installed	Two lamps, which can be lit simultaneously (one for warmup); manual switching	Operating temperature/humidity range	10 °C to 35 °C, 45 % to 80 % (70 % or less at 30 °C or higher.)
Lamp mode	Emission, Non-BGC, BGC-D <sub>2</sub>		
Chamber	Polypropylene		
Nebulizer	Ceramic impact bead, Pt/Ir capillary		
Burner head	Made of titanium, with a 10-cm slot (or a 5-cm slot for high-temperature flame optionally available)		

Note: The AA-6200 is not compatible with flames using hydrogen gas.

## Computer Requirements

Requires a computer, display, and printer satisfying the specifications noted below.

Operating environment with either of the following OS and user authority combinations:	Display	XGA (1024 × 768) or higher
Windows 7 Professional (32-bit version), standard user or higher	CPU	Pentium Dual Core Processor 2.0 GHz or higher
Windows XP Professional (32-bit version), power user or higher	HDD	At least 10 MB of free space is required to install AA control software.
RAM	CD/DVD drive	One CD drive (required to install software)
Windows 7: 2 GB or more	I/O port	One serial port (for AA control)
Windows XP: 1 GB or more		

Note: Windows is a registered trademark of Microsoft Corporation in the United States.

## Cautions Related to the Instrument Installation Site and Handling

Make sure that all required equipment is available before starting instrument installation.

For details, refer to the Pre-Installation Requirements.

### 1. Lab Bench

The bench must be at least 120 cm long and 60 cm deep, and must be sturdy enough to support 80 kg. During installation, leave 15 cm to 20 cm of space to the left and back of the instrument.

### 2. Ventilation

There is a risk of fire due to the combustible high-pressure gas used by the atomic absorption spectrophotometer, so be sure to ventilate the room.

### 3. Fires

Be careful of flames if you are measuring flammable samples. Be sure to install fire extinguishers in case of emergency.

### 4. Exhaust Ducts

Be sure to attach a duct to the top of the atomic absorption spectrophotometer to

discharge the exhaust gas from the burner.

### 5. Condensation

Avoid using this instrument in an environment subject to condensation. There is a risk of malfunctions in such a case.

### 6. Gas Piping

Be sure to position the gas cylinders outdoors, and install metal pipes to bring the gas to within 5 m of the instrument. (Min. inner diameter of 7 mm)

Do not use pipes containing copper, silver, or mercury materials (including alloys) for the acetylene piping.

Inspect the rubber hose section of the piping, and be particularly careful that it does not degrade and cause gas leaks.

Do not use oxygen.

### Example of Ventilation Setup

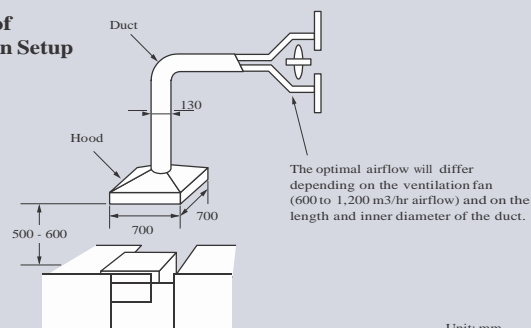

Unit: mm

### Example of Piping Recommended for the Atomic Absorption Spectrophotometer

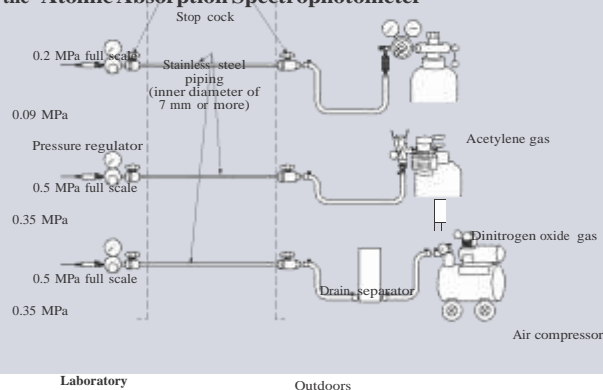

Note: The AA-6200 is not compatible with flames using hydrogen gas.

# Specifications



Shimadzu Corporation

[www.shimadzu.com/an/](http://www.shimadzu.com/an/)

Company names, product/service names and logos used in this publication are trademarks and trade names of Shimadzu Corporation or its affiliates, whether or not they are used with trademark symbol "TM" or "®".  
Third-party trademarks and trade names may be used in this publication to refer to either the entities or their products/services. Shimadzu disclaims any proprietary interest in trademarks and trade names other than its own.

For Research Use Only. Not for use in diagnostic procedures.  
The contents of this publication are provided to you "as is" without warranty of any kind, and are subject to change without notice. Shimadzu does not assume any responsibility or liability for any damage, whether direct or indirect, relating to the use of this publication.

© Shimadzu Corporation, 2014

Printed in Japan 3655-01408-20AIT