



## Lab Ultrasonic for Radial Probe

High volume treatment

## I Specifications of the Lab750 Ultrasonic for radial probe

### I.1 Equipment

- Ultrasonic generator from the NexTgen range delivering up to  $750W_{rms}$  in a continuous way,
- **20kHz ultrasonic radial probe including the 20kHz transducer,**
- **LabTablet interface for easy setting,**
- Control and monitoring software for the NexTgen generator,
- Optionally temperature control device composed of a temperature sensor and an acquisition unit connected to the ultrasonic generator to allow temperature monitoring
- Technical documentation.



### I.2 The NexTgen ultrasonic power generator

We therefore propose the use of a NexTgen Lab750 generator providing a rated power of  $750W_{rms}$ . The treatment is performed in a volume up to 500 to 1000ml.

The parameters of the generators from the NexTgen range can be defined by a LabTablet or by computer thanks to an Ethernet connection and a control software enabling the power tuning. This elementary setting software is called "Start" and is supplied with the generator. A general and technical documentation is added to the offer and describes the generator and its software features.

**Basic features:**

- A single control mode : auto-tuned frequency mode,
- On/Off by dry contact,
- A default feedback by dry contact
- The power setting can be done by computer and thanks to the "START" configuration software.

**Optional features:**

- Control parameters available through the "Advanced" PC software
- Acquisition of information on PC via Ethernet connection, recovery of ultrasound and temperature data for post-processing on Excel with the "NexTgen Advanced» PC software.

**I.3 The 20kHz Radial Probe:**

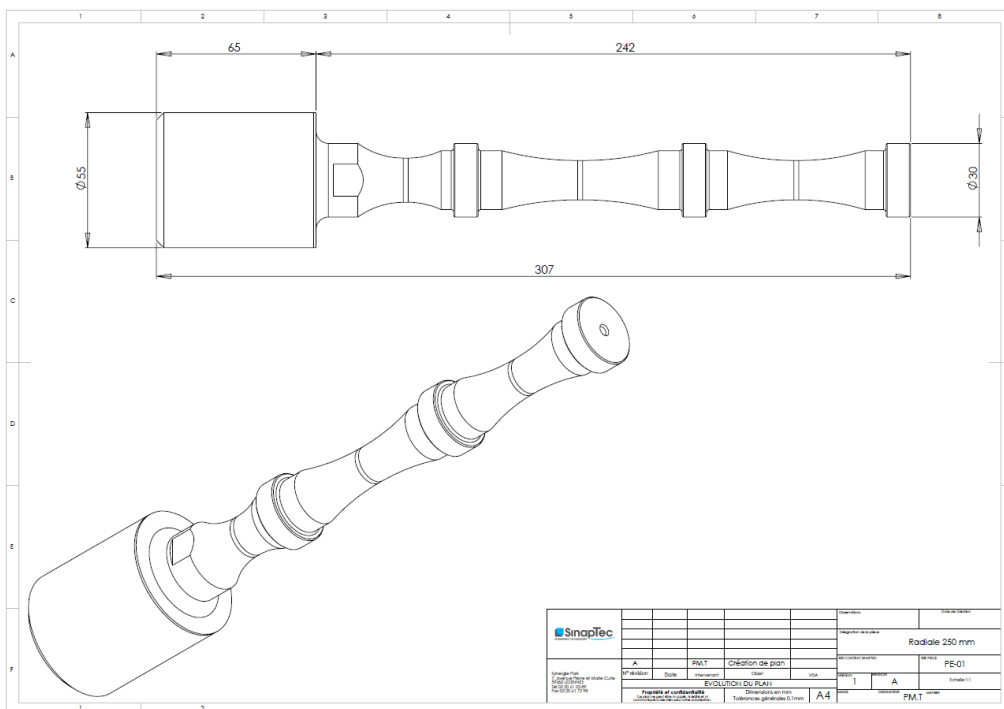

20 kHz Radial Probe size



20kHz Radial Probe inserted in a tube

- The probe deliver the ultrasound on all the length of the probe. The design increases the radial power emission and we can consider that 80% is delivered radially and 20% at the bottom of the probe.

The probes are ideally efficient if inserted in a tube. The diameter of the tube gives the ultrasonic intensity. The following table calculate the power by liter versus diameter of the tube.

Radial Probe Power (Watts Rms)	tube diameter (mm)	probe immersion (mm)	Sonicated volume (Liter)	Power/Liter W/L
400	50	220	0,4	1103
400	60	220	0,6	724
400	70	220	0,8	515
400	80	220	1,0	386
400	100	220	1,7	241

The proposed volume above is calculated to obtain a power density from 150Wrms/L to 1000Wrms/L. it is clearly possible to use the probe in bigger volume, but the power density will decrease. The probe can be inserted in tube from 45mm to 100mm.

The probe is adapted in batch or continuous flow working conditions. It is important **to cool the transducer in case of long duration process.**

## I.4 The control and data acquisition software (optional):

- **The “Advanced” PC software**

The software allows you to centralize all exchanges between the NexTgen generator and the PC control. It controls the start / stop system.

It allows you to configure the following settings:

- Frequency
- Amplitude / Power
- Time
- Cycle

It allows the following things:

- The real-time measurement of the power cycle,
- The graph visualization,
- Data export to Excel
- Various features analysis

- **Temperature control device**

The operation of the temperature control device is performed by the **“Advanced” PC software** which acquires data and processes them according to the same principle as the power curve. It is thus possible to have curves showing ultrasound measures in association with the evolution of the product temperature.

The temperature management -when it is to be regulated- is performed by setting a maximum operating threshold. As we approach this threshold, it will trigger a temporary reduction / stoppage of ultrasonic power supplied to return to normal temperature.



Synergie Park  
7, avenue Pierre et Marie Curie  
59260 LEZENNES  
FRANCE  
Tél : +33 (0)3 20 61 03 89  
Fax : +33 (0)3 20 61 72 98

e-mail : [sinaptec@sinaptec-ultrasonic.com](mailto:sinaptec@sinaptec-ultrasonic.com)

**[www.sinaptec-ultrasonic.com](http://www.sinaptec-ultrasonic.com)**